

## S-type load cell LC Tigo

Robust high-precision tension load cell



### ! Benefits

- Reliable weighing thanks to high resolution and accuracy class
- Specially designed for suspended vessel scales
- Versatile optional weighing electronics
- Design-in support from specialists

*Tension load cells from the LC Tigo series have been specially designed for weighing process vessels. Suspended mounting can better compensate for vessel movements.*

### Verifiable tension load cells for a variety of industrial applications

- ① The load cells developed in Germany guarantee the most accurate weighing results.  
**All load cells are verifiable according to OIML.**
- ① **For weighing processes and batching applications** which require tension weighing.
- ① A comprehensive optional portfolio of **transmitters, indicators and controllers** ensures reliable continuous processing of the measurement signals as desired.
- ① Comprehensive expertise in scale production ensures **high-quality advice** for individual projects.

The right solution for all of these applications:



Weighing



Filling and dosing



Fill quantity control

## Technical specifications

S-type load cell LC Tigo					
Parameters	Description	Abbr.	PR 76 N	PR 76 C3	Unit
Accuracy class			0.03	0.025	% E <sub>max</sub>
Minimum dead load	Lowest limit of specified measuring range	E <sub>min</sub>	0		% E <sub>max</sub>
Maximum capacity	Highest limit of specified measuring range	E <sub>max</sub>	60, 125, 250, 500, 1,000, 2,000, 3,000, 5,000		kg
Maximum usable load	Upper limit for measurements	E <sub>lim</sub>	150		% E <sub>max</sub>
Destructive load	Danger of mechanical destruction	E <sub>d</sub>	300		% E <sub>max</sub>
Minimum LC verification	Minimum load cell verification interval, $v_{min} = E_{max}/Y$	Y	/	8,333	
Deadload output return	Factor for deadload output return after load (DR = 1/2 * E <sub>max</sub> /Z)	Z	/	3,000	
Rated output	Relative output at maximum capacity	C <sub>n</sub>	2		mV/V
Tolerance on rated output	Permissible deviation from rated output	d <sub>c</sub>	< 0.25		%C <sub>n</sub>
Zero output signal	Load cell output signal under unloaded condition	S <sub>min</sub>	0 ± 2		%C <sub>n</sub>
Repeatability error	Max. change in load cell output for repeated loading	e <sub>R</sub>	< 0.012		%C <sub>n</sub>
Creep	Max. change of output signal at E <sub>max</sub> during 30 min.	d <sub>cr</sub>	< 0.030	< 0.017	%C <sub>n</sub>
Non-linearity <sup>1)</sup>	Deviation from best straight line through zero	d <sub>lin</sub>	< 0.030	< 0.017	%C <sub>n</sub>
Hysteresis <sup>1)</sup>	Max. difference in LC output between loading and unloading	d <sub>hy</sub>	< 0.030	< 0.017	%C <sub>n</sub>
Temperature effect on S <sub>min</sub>	Max. change of S <sub>min</sub> over B <sub>T</sub>	TK <sub>Smin</sub>	< 0.028	< 0.017	%C <sub>n</sub> /10K
Temperature effect on C <sup>1)</sup>	Max. change of C in B <sub>T</sub>	TK <sub>C</sub>	< 0.025	< 0.011	%C <sub>n</sub> /10K
Input impedance	Between supply terminals	R <sub>LC</sub>	400 ± 50		Ω
Output impedance	Between measuring terminals	R <sub>O</sub>	352 ± 3		Ω
Insulation impedance	Between measuring circuit and housing at 100 V <sub>DC</sub>	R <sub>IS</sub>	> 5,000 × 10 <sup>6</sup>		Ω
Recommended supply voltage range	To hold the specified performance	B <sub>u</sub>	≤ 10		V
Max. supply voltage	Continuous operation without damage	U <sub>max</sub>	15		V
Nominal ambient temp. range	To hold the specified performance	B <sub>T</sub>	-10 to +40 <sup>2)</sup>		°C
Usable ambient temp. range	Continuous operation without damage	B <sub>TU</sub>	-30 to +70		°C
Storage temperature range	Without electrical and mechanical stress	B <sub>Ti</sub>	-30 to +70		°C
Barometric pressure influence	Influence of barometric pressure on output		≤ 0.004		%C <sub>n</sub> /kPa
Nominal deflection	Max. elastic deformation under maximum capacity	S <sub>nom</sub>	0.2 (E <sub>max</sub> = 60 kg ... 500 kg); 0.3 (E <sub>max</sub> = 1 t ... 5 t)		mm
Sensor material	Stainless steel				
Cable length			5		m
IP protection class	According to EN 60529		IP66 + IP67		

<sup>1)</sup> The data for non-linearity (d<sub>lin</sub>), hysteresis (d<sub>hy</sub>) and temperature effect on C (TK<sub>C</sub>) are typical values. For OIML R60 or NTEP approved load cells, the sum of these values is within the permissible cumulative error limits.

<sup>2)</sup> 60 kg (0°C - +40°C)

Accuracy classes and minimum verification interval, v <sub>min</sub>										
Maximum capacity	Maximum number of verification intervals, n <sub>max</sub>	60 kg	125 kg	250 kg	500 kg	1,000 kg	2,000 kg	3,000 kg	5,000 kg	Unit
OIML	3,000	0.007	0.015	0.030	0.060	0.120	0.240	0.360	0.600	kg
NTEP Class III Multiple	5,000	0.007	0.015	0.030	0.060	0.120	0.240	0.360	0.600	kg
NTEP Class III L Multiple	10,000	0.003	0.007	0.013	0.025	0.050	0.100	0.150	0.250	kg

# Technical diagrams

## S-type load cell LC Tigo

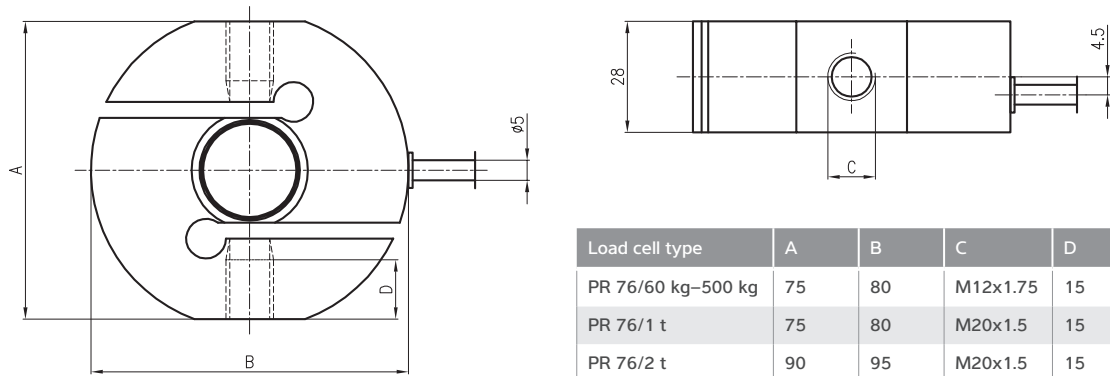

Load cell type	A	B	C	D
PR 76/60 kg–500 kg	75	80	M12x1.75	15
PR 76/1 t	75	80	M20x1.5	15
PR 76/2 t	90	95	M20x1.5	15
PR 76/3 t–5 t	120	125	M20x1.5	20

S-type load cell LC Tigo PR 76

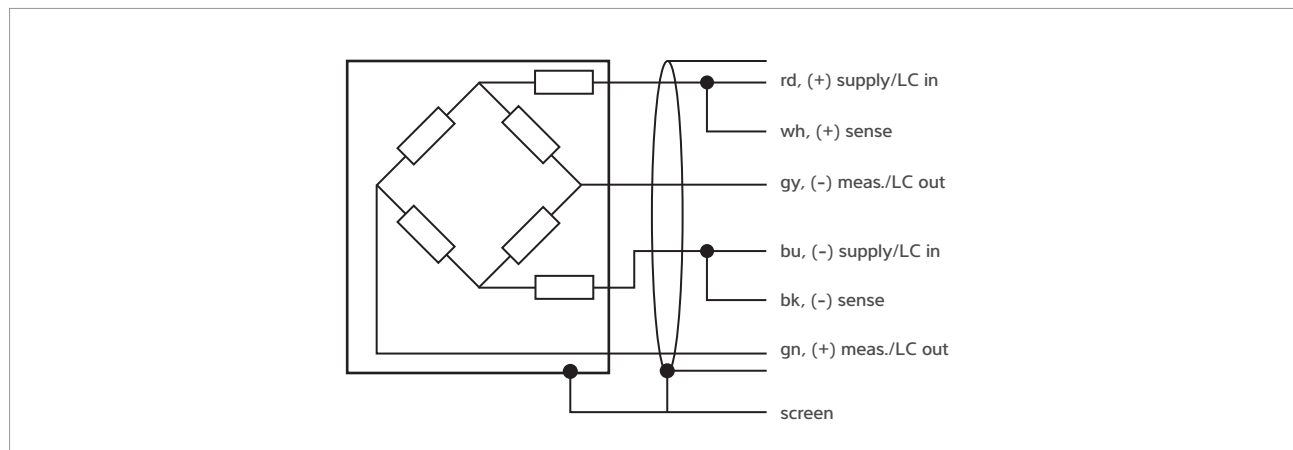

Circuit diagram

## Load cell accessory – rod end PR 96

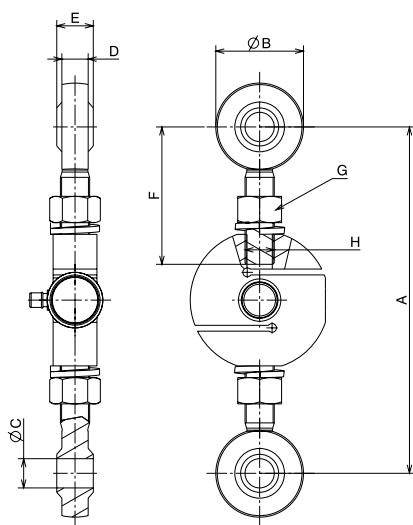

Load cell type	A	B	C	D
PR 76/60 kg–500 kg	155 ± 1	32	12	7
PR 76/1 t	203 ± 1	50	20	18
PR 76/2 t	218 ± 1	50	20	18
PR 76/3 t–5 t	238 ± 1	50	20	18

Load cell type	E	F	G	H
PR 76/60 kg–500 kg	10	54	A/F19	M12x1.75
PR 76/1 t	25	78	A/F30	M20x1.5
PR 76/2 t	25	78	A/F30	M20x1.5
PR 76/3 t–5 t	25	78	A/F30	M20x1.5

The stated values apply only for static and quasistatic applications

All dimensions in mm

## Ex approval

### Scope of validity:

LC Tigo (PR 76)



Explosion protection

## S-type load cell LC Tigo certificates

Zone	Marking	Certificate number	For
2	II 3G Ex nA IIC T6 Gc	Manufacturer's declaration	All PR 76/xx
22	II 3D Ex tc IIIC T85 °C Dc		

## Ordering information

S-type load cell LC Tigo, C3	
Type	Order number
PR 76/60 kg C3	9409 276 03060
PR 76/125 kg C3	9409 276 03112
PR 76/250 kg C3	9409 276 03125
PR 76/500 kg C3	9409 276 03150
PR 76/1,000 kg C3	9409 276 03210
PR 76/2,000 kg C3	9409 276 03220
PR 76/3,000 kg C3	9409 276 03230
PR 76/5,000 kg C3	9409 276 03250

S-type load cell LC Tigo, N	
Type	Order number
PR 76/60 kg N	9409 276 01060
PR 76/125 kg N	9409 276 01112
PR 76/250 kg N	9409 276 01125
PR 76/500 kg N	9409 276 01150
PR 76/1,000 kg N	9409 276 01210
PR 76/2,000 kg N	9409 276 01220
PR 76/3,000 kg N	9409 276 01230
PR 76/5,000 kg N	9409 276 01250

Load cell accessory S-type load cell LC Tigo		
Type	Description	Order number
PR 96/00N	Ball head for PR 76 up to 500 kg	9405 300 96001
PR 96/01N	Ball head for PR 76 1 t–5 t	9405 300 96011
PR 6143/80	Constrainer for transverse forces of <2 kN	9405 361 43801

The products and solutions presented in this data sheet make major contributions in the following sectors:



Food and beverages



Agribusiness



Building materials



Machinery (OEM)

The technical data given serves as a product description only and should not be understood as guaranteed properties in the legal sense.

Specifications subject to change without notice.  
Rev. 03/2020

Minebea Intec GmbH  
Meiendorfer Straße 205 A  
22145 Hamburg, Germany  
Phone +49.40.67960.303  
sales.hh@minebea-intec.com  
www.minebea-intec.com