

Weighing module Contego®

For the hygienic, safe and accurate weighing of process vessels



Hygienic Design



German Quality

 The weighing module Contego® is intended for the hygienic weighing of process vessels and has been specifically designed to be easy to clean, as well as meeting another of the key criteria for safe and efficient manufacturing processes by avoiding hygienically critical areas. The hygienically safe combination of a load cell and mounting kit was developed on the basis of EHEDG directive and helps to prevent product contamination.

The right solution for all of these applications:



Weighing



Filling and dosing

Technical specifications

Weighing module Contego®					
Parameter	Description	Abbr.	D1	C3	Unit
Accuracy class			0.04	0.015	%E _{max}
Minimum dead load	Lowest limit of specified measuring range	E _{min}	0		%E _{max}
Maximum capacity	Highest limit of specified measuring range	E _{min}	See Ordering information table		%E _{max}
Safe load limit	Maximum load without irreversible damage	E _{lim}	150		%E _{max}
Destructive load	Danger of mechanical destruction	E _d	> 300		%E _{max}
Minimum load cell verification interval (OIML) For NTEP, see separate table	Minimum load cell verification interval, $V_{min} = E_{max}/Y$	Y	5,000	14,000	
Deadload output return	Factor for deadload output return after load (DR = 1/2 * E _{max} / Z)	Z	1,000	3,000	
Rated output	Relative output at maximum capacity	C _n	2		mV/V
Tolerance on rated output	Permissible deviation from rated output	d _c	<0.25	<0.07	%C _n
Zero output signal	Load cell output signal under unloaded condition	S _{min}	<1.0	<1.0	%C _n
Reproducibility	Max. change in load cell output for repeated loading	ε _R	<0.01	<0.005	%C _n
Creep	Max. change of output signal at E _{max} during 30 minutes	d _{cr}	<0.03	<0.015	%C _n
Non-linearity	Max. deviation from best straight line through zero	d _{lin}	<0.03	<0.01	%C _n
Hysteresis	Max. difference in LC output between loading and unloading	d _{hy}	<0.04	<0.015	%C _n
Temperature effect (TK) on S _{min}	Max. change of S _{min} in B _T	TK _{Smin}	<0.028	<0.01	%C _n /10 K
Temperature effect (TK) on parameter	Max. change of C in B _T	TK _C	<0.03	<0.01	%C _n /10 K
Input impedance	Between supply terminals	R _{LC}	650 ± 6		Ω
Output impedance	Between measuring terminals	R _O	610 ± 1	610 ± 0.5	Ω
Insulation impedance	Between measuring circuit and housing at 100 V _{DC}	R _{IS}	> 5,000 × 10 ⁶		Ω
Insulation voltage	Between circuit and housing (only for Contego® incl. PR 6241/..E)		500		V
Recommended supply voltage	To hold the specified performance	B _u	4...24		V
Max. supply voltage	Permissible for continuous operation without damage	U _{max}	28 (Ex versions: 25)		V
Nominal ambient temp. range	To hold the specified performance	B _T	-10...+55		°C
Usable ambient temp. range	Permissible for continuous operation without damage	B _{Tu}	-40...+95		°C
Storage temperature range	Without electrical and mechanical stress	B _{Ti}	-40...+95		°C
Permissible eccentricity	Permissible displacement from nominal load line	S _{ex}	5		mm
Vibration resistance	Resistance against oscillations (IEC 68-2-6-Fc)		20 g, 100 h, 10... 150 Hz		
Barometric pressure influence	Influence of barometric pressure on output	PK _{Smin}	<0.005	<0.0025	%C _n /kPa
Nominal deflection	Max. elastic deformation under maximum capacity	S _{nom}	≤0.3		mm
Permissible horizontal force	7 kN				

Parameter	Description	Abbr.	D1	C3	Unit
Permissible vertical load without load cell	1.5 t				
Permissible lift-off force	8 kN				
Permissible force for jack-up	15 kN				
Material	Sensor: stainless steel 1.4542 Mounting kit: stainless steel 1.4404 Bellows: silicon (FDA-compliant)				
Protection class	IP68/IP69				
Cable	Length: 5 m Diameter: 5 mm Cross-section: 4 x 0.35 mm ² Cable sheath material: TPE				
Bending radius	≥ 25 mm in case of fixed installation ≥ 75 mm in case of flexible installation				

NTEP classification PR 6241

NTEP			NTEP minimum load cell verification interval, v_{min}						
Maximum capacity	with OIML class	divisions n_{max}	100 kg	200 kg	300 kg	500 kg	1 t	2 t	Unit
Class III Multiple	D1	2,000	20	40	60	100	200	400	g
Class III Multiple	C3	5,000	--	14.3	21	36	71	143	g
Class III L Multiple	D1	5,000	6.7	13.3	20	33	67	133	g
Class III L Multiple	C3	10,000	--	5	7.1	12	24	48	g

Load cell PR 6241

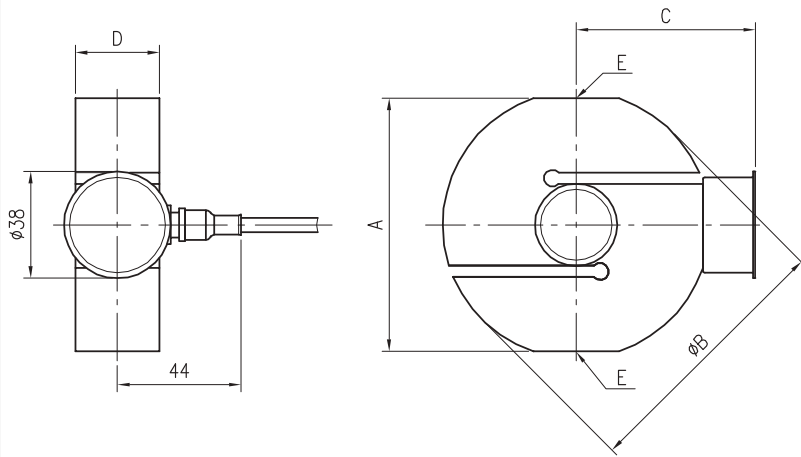

Model	A [mm]	B [mm]	C [mm]	D [mm]	E [mm]
PR 6241/ 12...52	60	65	50	23	M12
PR 6241/ 13...23	60	65	50	30	M12

Adapter plate PR 6041/80S

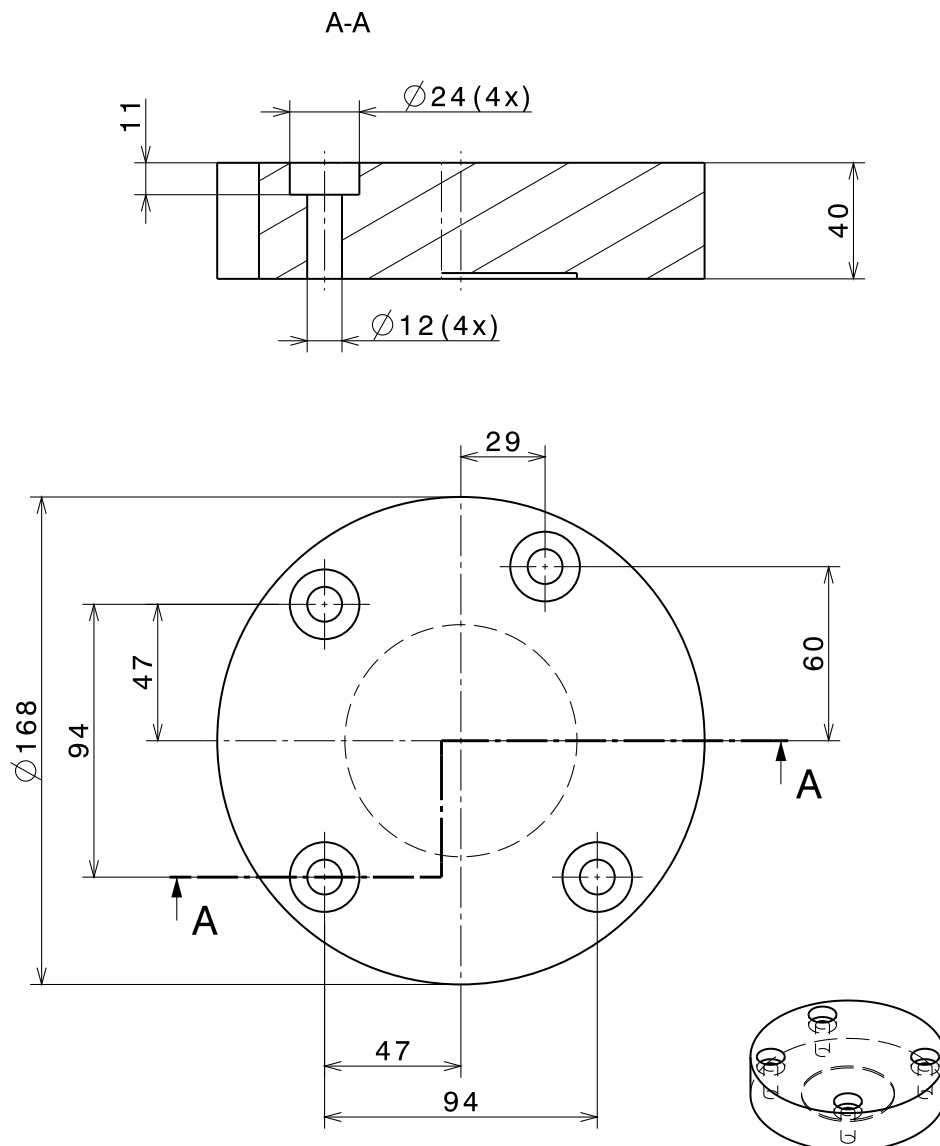

Ex approval

Scope of validity:

Weighing module Contego®



Explosion protection

Certificates for load cell PR 6241

Zone	Labelling	Certificate number	For
0 and 1	II 1G Ex ia IIC T6 Ga Ex ia IIC T6 Ga	BVS 16 ATEX E 005 IECEX BVS 16.0005	Contego® all types with "Ex"
20 and 21	II 1D Ex ta IIIC T160 °C Da Ex ta IIIC T160°C Da	TÜV 03 ATEX 2301X IECEX TUN 17.0025X	Contego® all types without "Ex"
2	II 3G Ex nA IIC T6 Gc	Manufacturer's declaration	Contego® all types without "Ex"
22	II 3D Ex tc IIIC T85 °C Dc	Manufacturer's declaration	Contego® all types without "Ex"

Notice! The weighing module Contego® incl. the load cell PR 6241 is subject to the following restrictions:

Gas explosions:

Suitable for Zones 1 and 2 and explosion subgroups IIA and IIB.

Dust explosions:

Suitable for Zones 21 and 22 and explosion subgroup III if the following safety instructions are observed:

- Electrostatic charging of the folding bellows must be avoided.
- The Contego® must be permanently installed.



Ordering information

Weighing module Contego® incl. load cell PR 6241,
accuracy class D1 = 0.04%, cable outlet at side

Type	Order number
Contego® 100 kg D1 A	940524161110
Contego® 200 kg D1 A	940524161120
Contego® 300 kg D1 A	940524161130
Contego® 500 kg D1 A	940524161150
Contego® 1,000 kg D1 A	940524161210
Contego® 2,000 kg D1 A	940524161220

Weighing module Contego® incl. load cell PR 6241,
accuracy class C3 = 0.015%, cable outlet at side

Type	Order number
Contego® 200 kg C3 A	940524163120
Contego® 300 kg C3 A	940524163130
Contego® 500 kg C3 A	940524163150
Contego® 1,000 kg C3 A	940524163210
Contego® 2,000 kg C3 A	940524163220

Weighing module Contego® incl. load cell PR 6241,
accuracy class C3 = 0.015%, cable outlet at side, Ex version

Type	Order number
Contego® 200 kg C3 Ex A	940524163120
Contego® 500 kg C3 Ex A	940524163150
Contego® 1,000 kg C3 Ex A	940524163210

Accessories

Adapter plate PR 6041/80S	
Type	Order number
PR 6041/80S	940536041802

The products and solutions presented in this data sheet make major contributions in the following sectors:



Food and beverages



Pharmaceutical



Chemical

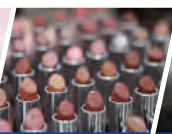

Cosmetics



Machinery (OEM)

The technical data given serves as a product description only and should not be understood as guaranteed properties in the legal sense.

Specifications subject to change without notice.
Rev. 12/2018

Minebea Intec GmbH
Meiendorfer Straße 205 A
22145 Hamburg, Germany
Phone +49.40.67960.303
sales.hh@minebea-intec.com
www.minebea-intec.com