

Single Point load cells PR 57 & PR 58

Weighing solution with high precision

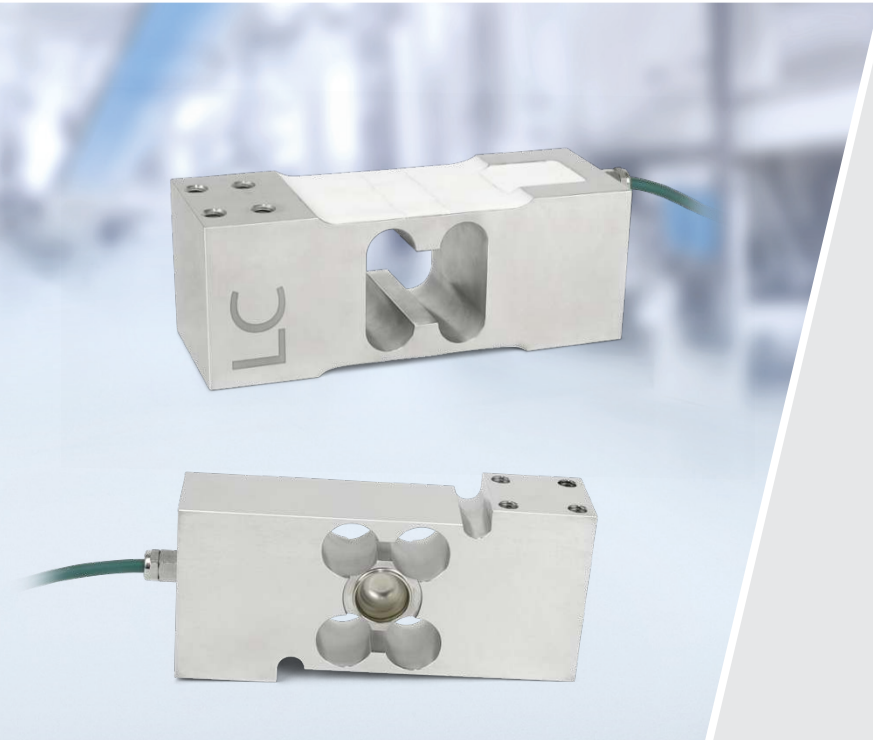

! Benefits

- Reliable weighing results
- Corrosion-resistant for demanding applications
- For a wide range of loads
- Versatile optional weighing electronics
- Design-in support from specialists

Ideal for integration in floor scales: with the Single Point load cells PR 57 and PR 58, you can rely on the tried-and-tested quality of a leading manufacturer of industrial weighing technology. Suitable for load ranges of 100 kg to 500 kg and a platform size of up to 600 mm × 600 mm.

Verifiable load cells for a variety of industrial applications

- ! These load cells, developed in Germany, guarantee the most accurate weighing results. **All load cells are verifiable according to OIML and NTEP.**
- ! **Specifically for floor platform scales.** Loads from 100 kg to 500 kg. Stainless steel ensures a long product lifetime.
- ! A comprehensive optional portfolio of **transmitters, indicators and controllers** ensures reliable continuous processing of the measurement signals as desired.
- ! Comprehensive expertise in scale production ensures **high-quality advice** for individual projects.

Technical specifications

Single Point load cells PR 57 and PR 58

Parameter	Description	Abbr.	PR 57 C3MR	PR 58 C3MR	Unit
Accuracy class			0.02		% E _{max}
Minimum dead load	Lowest limit of specified measuring range	E _{min}	0		% E _{max}
Maximum capacity	Highest limit of specified measuring range	E _{max}	300, 500	100, 250, 500	kg
Maximum usable load	Upper limit for measurements	E _{lim}	150		% E _{max}
Destructive load	Danger of mechanical destruction	E _d	300		% E _{max}
Minimum LC verification	Minimum load cell scale interval, $v_{min} = E_{max}/Y$	Y	15000		
Deadload output return	Factor for deadload output return after load ($DR = 1/2 * E_{max}/Z$)	Z	3000		
Rated output	Relative output at maximum capacity	C _n	2		mV/V
Tolerance on rated output	Permissible deviation from rated output	d _c	< 10		%C _n
Zero output signal	Load cell output signal under unloaded condition	S _{min}	0 ± 5		%C _n
Repeatability error	Max. change in load cell output for repeated loading	ε _R	< 0.01		%C _n
Creep	Max. change of output signal at E _{max} during 30 min.	d _{cr}	< 0.0166		%C _n
Non-linearity ¹⁾	Deviation from best straight line through zero	d _{Lin}	< 0.0166		%C _n
Hysteresis ¹⁾	Max. difference in LC output between loading and unloading	d _{hy}	< 0.0166		%C _n
Temperature effect (TK) on S _{min}	Max. change related to C _n of S _{min} per 10K in B _T	TK _{Smin}	< 0.0093		%C _n /10 K
TK on parameter ¹⁾	Max. change related to C _n of C per 10K in B _T	TK _C	< 0.0117		%C _n /10 K
Off-centre load error	In compliance with the technical data according to OIML R76		0.0233		%C _n
Input impedance	Between supply terminals	R _{LC}	380 ± 38		Ω
Output impedance	Between measuring terminals	R _O	350 ± 25		Ω
Insulation impedance	Between measuring circuit and housing at 100 V _{DC}	R _{IS}	> 5,000 × 10 ⁶		Ω
Nominal supply voltage range	To hold the specified performance	B _u	≤ 12		V _{DC}
Max. supply voltage	Continuous operation without damage	U _{max}	15		V _{DC}
Nominal ambient temp. range	To hold the specified performance	B _T	-10 ... +40		°C
Usable ambient temp. range	Continuous operation without damage	B _{Tu}	-20 ... +65	-30 ... +70	°C
Storage temperature range	Without electrical and mechanical stress	B _{Ti}	-25 ... +70	-50 ... +80	°C
Barometric pressure influence	Influence of barometric pressure on output		< 0.007		%C _n /kPa
Nominal deflection	Max. elastic deformation under maximum capacity	S _{nom}	< 0.7	< 0.2	mm
Cable length			3		m
Material	Stainless steel				
Max. platform size	In compliance with the technical data according to OIML R76		600 × 600		mm × mm
IP protection class	According to EN 60529		IP66/IP67	IP66/IP68	

¹⁾ Non-linearity (d_{Lin}), hysteresis (d_{hy}) and parameter temperature effect (TK_C) are typical values. For OIML R60- and NTEP-approved load cells, the total of these values is within the permitted cumulative error limits.

Accuracy classes and minimum scale interval, v_{min}

	Maximum number of scale intervals, n _{max}	PR 57/ 300 kg	PR 57/ 500 kg	PR 58/ 100 kg	PR 58/ 250 kg	PR 58/ 500 kg	Unit
OIML	3000	0.020	0.033	0.007	0.017	0.033	kg
NTEP Class III Multiple	5000	0.020	0.033	0.007	0.017	0.033	kg

Technical diagrams

Single Point load cell PR 57

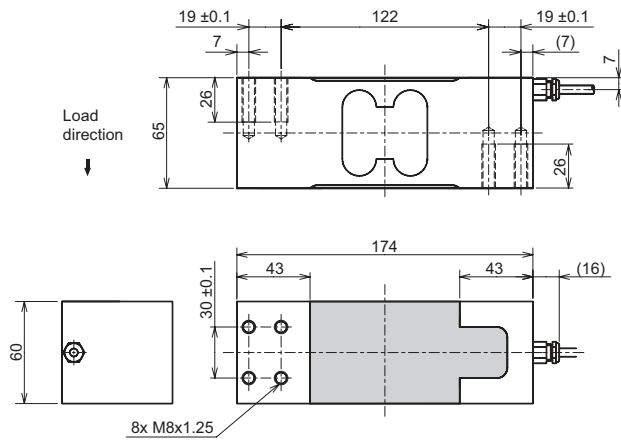

Single Point load cell PR 58

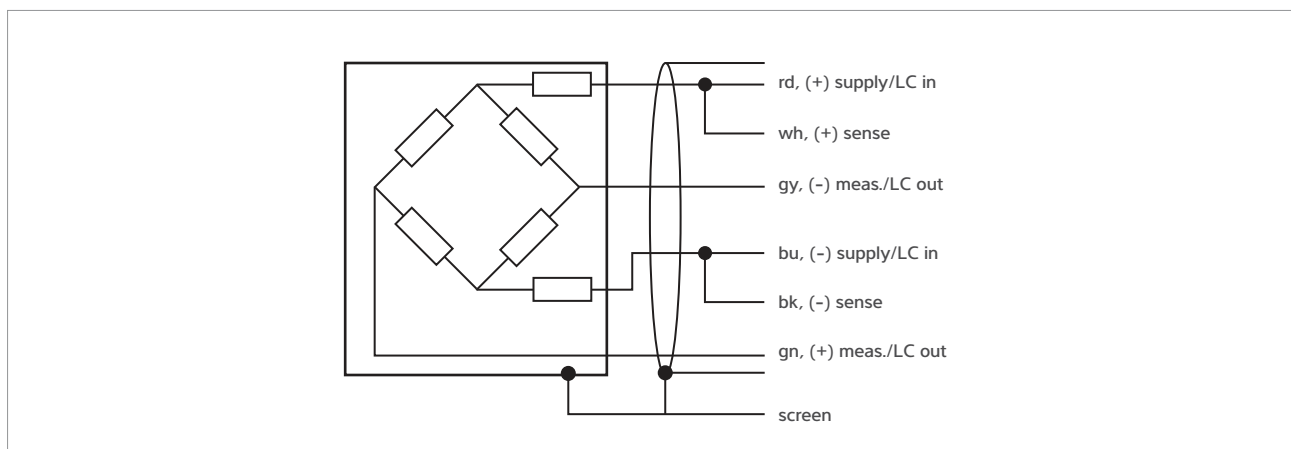
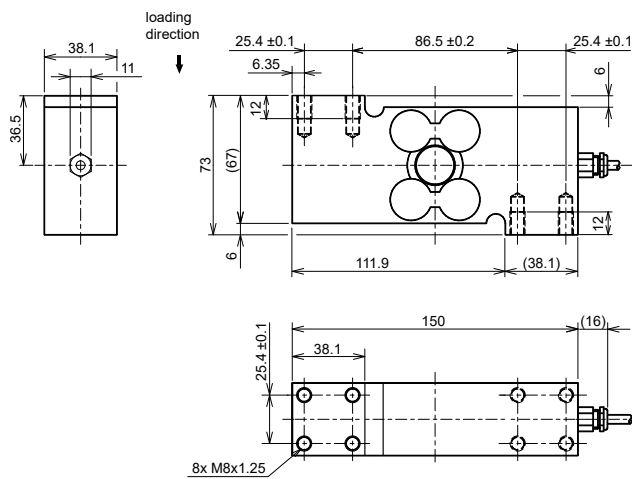

Circuit diagram

Ex approval



Explosion protection

Scope of validity:

Single Point load cell LC stainless steel

Single Point load cells PR 57 and PR 58 certificates

Zone	Marking	Certificate number	For
0	II 1G Ex ia IIC T6/T4 Ga	BVS 21 ATEX E 023 X IECEx BVS 21.0024X	Only PR 5x/xx E
20	II 1D Ex ia IIIC T ₂₀₀ 165°C Da		
2	II 3G Ex ec IIC T6/T4 Gc		All PR 5x without E
21	II 2D Ex tb IIIC T110°C Db		

Ordering information

Single Point load cell PR 57

Model	Order number
PR 57/300 kg C3MR	9409 257 07130
PR 57/500 kg C3MR	9409 257 07150
PR 57/300 kg C3MRE	9409 657 07130
PR 57/500 kg C3MRE	9409 657 07150
PR 57/300 kg III 5000 S	9409 257 0C130
PR 57/500 kg III 5000 S	9409 257 0C150

Single Point load cell PR 58

Model	Order number
PR 58/100 kg C3MR	9409 258 07110
PR 58/250 kg C3MR	9409 258 07125
PR 58/500 kg C3MR	9409 258 07150
PR 58/100 kg C3MRE	9409 658 07110
PR 58/250 kg C3MRE	9409 658 07125
PR 58/500 kg C3MRE	9409 658 07150
PR 58/100 kg III 5000 S	9409 258 0C110
PR 58/250 kg III 5000 S	9409 258 0C125
PR 58/500 kg III 5000 S	9409 258 0C150

The products and solutions presented in this data sheet make major contributions in the following sectors:



The technical data given serves as a product description only and should not be understood as guaranteed properties in the legal sense.

Specifications subject to change without notice.
Rev. 09/2023

Minebea Intec GmbH
Meiendorfer Strasse 205 A
22145 Hamburg, Germany
Phone +49.40.67960.303
sales.hh@minebea-intec.com
www.minebea-intec.com