

Single Point load cell PR 57

Weighing solution with high precision

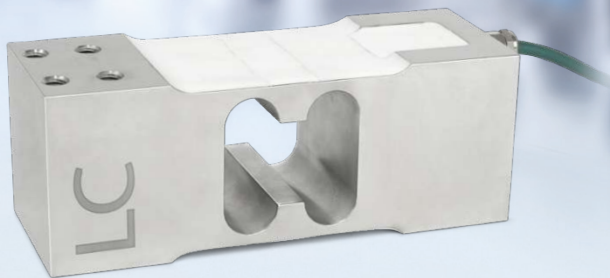

! Benefits

- Reliable weighing through accurate measurement results
- Corrosion-resistant for demanding applications
- For a wide range of loads
- Versatile optional weighing electronics
- Design-in support from specialists

Ideal for integration in floor scales, for example: with the Single Point load cell PR 57, you can rely on the tried-and-tested quality of a leading manufacturer of industrial weighing technology. Suitable for load ranges of 300 kg to 500 kg and a platform size of up to 600 mm × 600 mm.

Verifiable load cells for a variety of industrial applications

- ! These load cells, developed in Germany, guarantee the most accurate weighing results. **All load cells are verifiable according to OIML and NTEP.**
- ! **Specifically for floor platform scales.** Loads from 300 kg to 500 kg. Stainless steel ensures a long product lifetime.
- ! A comprehensive optional portfolio of **transmitters, indicators and controllers** ensures reliable continuous processing of the measurement signals as desired.
- ! Comprehensive expertise in scale production ensures **high-quality advice** for individual projects.

Technical specifications

Single Point load cell PR 57				
Parameter	Description	Abbr.	PR 57 C3MR	Unit
Accuracy class			0.02	% E_{max}
Minimum dead load	Lowest limit of specified measuring range	E_{min}	0	% E_{max}
Maximum capacity	Highest limit of specified measuring range	E_{max}	300, 500	kg
Maximum usable load	Upper limit for measurements	E_{lim}	150	% E_{max}
Destructive load	Danger of mechanical destruction	E_d	300	% E_{max}
Minimum LC verification	Minimum load cell scale interval, $v_{min} = E_{max}/Y$	Y	15000	
Deadload output return	Factor for deadload output return after load ($DR = 1/2 * E_{max}/Z$)	Z	3000	
Rated output	Relative output at maximum capacity	C_n	2	mV/V
Tolerance on rated output	Permissible deviation from rated output	d_c	< 10	% C_n
Zero output signal	Load cell output signal under unloaded condition	S_{min}	0 ± 5	% C_n
Repeatability error	Max. change in load cell output for repeated loading	ϵ_R	< 0.01	% C_n
Creep	Max. change of output signal at E_{max} during 30 min.	d_{cr}	0.0166	% C_n
Non-linearity ¹⁾	Deviation from best straight line through zero	d_{lin}	0.0166	% C_n
Hysteresis ¹⁾	Max. difference in LC output between loading and unloading	d_{hy}	0.0166	% C_n
Temperature effect (TK) on S_{min}	Max. change related to C_n of S_{min} per 10K in B_T	$TK_{S_{min}}$	< 0.0093	% C_n /10 K
TK on parameter ¹⁾	Max. change related to C_n of C per 10K in B_T	TK_C	< 0.0117	% C_n /10 K
Off-centre load error	In compliance with the technical data according to OIML R76		0.0233	% C_n
Input impedance	Between supply terminals	R_{LC}	380 ± 38	Ω
Output impedance	Between measuring terminals	R_O	350 ± 25	Ω
Insulation impedance	Between measuring circuit and housing at 100 V _{DC}	R_{IS}	> 5,000 × 10 ⁶	Ω
Nominal supply voltage range	To hold the specified performance	B_u	≤ 12	V _{DC}
Max. supply voltage	Continuous operation without damage	U_{max}	15	V _{DC}
Nominal ambient temp. range	To hold the specified performance	B_T	-10 to +40	°C
Usable ambient temp. range	Continuous operation without damage	B_{Tu}	-20 to +65	°C
Storage temperature range	Without electrical and mechanical stress	B_{Ti}	-25 to +70	°C
Barometric pressure influence	Influence of barometric pressure on output		< 0.007	% C_n /kPa
Nominal deflection	Max. elastic deformation under maximum capacity	S_{nom}	< 0.7	mm
Cable length			3	m
Material	Stainless steel			
Max. platform size	In compliance with the technical data according to OIML R76		600 × 600	mm × mm
IP protection class	According to EN 60529		IP66/IP67	

¹⁾ Non-linearity (d_{lin}), hysteresis (d_{hy}) and parameter temperature effect (TK_C) are typical values. For OIML R60- and NTEP-approved load cells, the total of these values is within the permitted cumulative error limits.

Accuracy classes and minimum scale interval, v_{min}				
	Maximum number of scale intervals, n_{max}	PR 57/300 kg	PR 57/500 kg	Unit
OIML	3000	0.020	0.033	kg
NTEP Class III Multiple	5,000	0.020	0.033	kg

Technical diagrams

Single Point load cell PR 57

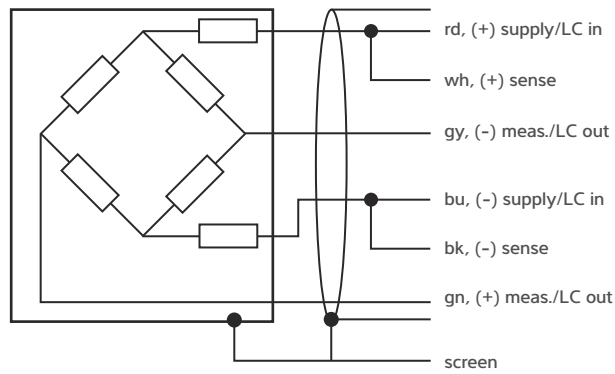
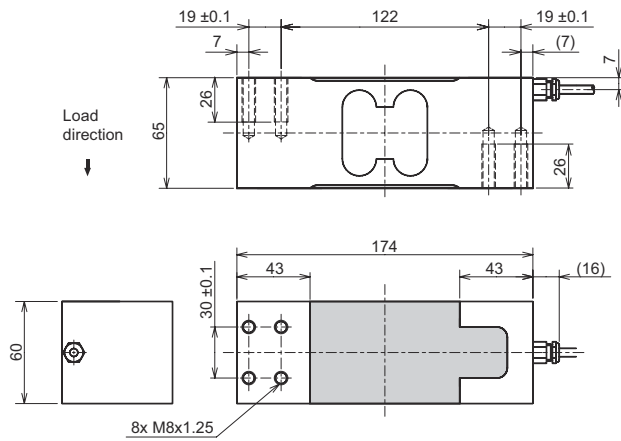

Circuit diagram

Ex approval



Explosion protection

Scope of validity:

Single Point load cell LC stainless steel

Single Point load cell PR 57 certificates

Zone	Marking	Certificate number	For
0 and 1	II 1G Ex ia IIC T6/T4 Ga	BVS 21 ATEX E 023 X IECEX BVS 21.0024X	Only PR 5x/xx E
20	II 1D Ex ia IIIC T ₂₀₀ 165°C Da		
2	II 3G Ex ec IIC T6/T4 Gc		All PR 5x without E
21	II 2D Ex tb IIIC T110°C Db		

Ordering information

Single Point load cell PR 57

Model	Order number
PR 57/300 kg C3MR	9409 257 07130
PR 57/500 kg C3MR	9409 257 07150
PR 57/300 kg C3MRE	9409 657 07130
PR 57/500 kg C3MRE	9409 657 07150
PR 57/300 kg III 5000 S	9409 257 0C130
PR 57/500 kg III 5000 S	9409 257 0C150

The products and solutions presented in this data sheet make major contributions in the following sectors:



Food and beverages



Chemistry



Agribusiness



Building materials



Machinery (OEM)

The technical data given serves as a product description only and should not be understood as guaranteed properties in the legal sense.

Specifications subject to change without notice.

Rev. 04/2023

Minebea Intec GmbH
 Meiendorfer Strasse 205 A
 22145 Hamburg, Germany
 Phone +49.40.67960.303
 sales.hh@minebea-intec.com
 www.minebea-intec.com