

Single Point load cell PR 55

Precise measuring results for scale construction and a wide range of industrial applications.



! Benefits

- Extremely high Y value for the most accurate measurement results
- Corrosion-resistant for demanding applications
- For a wide range of loads
- Versatile optional weighing electronics
- Design-in support from specialists

With the Single Point load cell PR 55, you can rely on the tried-and-tested quality of a leading manufacturer of industrial weighing technology. The stainless steel Single Point load cell PR 55 is suitable for loads ranging from 11 kg to 200 kg and a platform size of 500 mm x 400 mm.

Verifiable load cells for a variety of industrial applications

- ! These load cells, developed in Germany, guarantee the most accurate weighing results.
All load cells are verifiable according to OIML and NTEP.
- ! A comprehensive optional portfolio of **transmitters, indicators and controllers** ensures reliable continuous processing of the measurement signals as desired.
- ! **The PR 55 covers a load spectrum from 11 kg to 200 kg.** Stainless steel ensures a long product life-time.
- ! Comprehensive expertise in scale production ensures **high-quality advice** for individual projects.

Technical specifications

Single Point load cell PR 55				
Parameter	Description	Abbr.	PR 55 C3MR	Unit
Accuracy class			0.02	% E_{max}
Minimum dead load	Lowest limit of specified measuring range	E_{min}	0	% E_{max}
Maximum capacity	Highest limit of specified measuring range	E_{max}	11, 22, 50, 100, 200	kg
Maximum usable load	Upper limit for measurements	E_{lim}	150	% E_{max}
Destructive load	Danger of mechanical destruction	E_d	300	% E_{max}
Minimum LC verification	Minimum load cell scale interval, $v_{min} = E_{max}/Y$	Y	22,000 (11 kg and 22 kg) 25,000 (from 50 kg)	
Deadload output return	Factor for deadload output return after load ($DR = 1/2 * E_{max}/Z$)	Z	3000	
Rated output	Relative output at maximum capacity	C_n	2	mV/V
Tolerance on rated output	Permissible deviation from rated output	d_c	< 10	% C_n
Zero output signal	Load cell output signal under unloaded condition	S_{min}	0 ± 5	% C_n
Repeatability error	Max. change in load cell output for repeated loading	ϵ_R	< 0.01	% C_n
Creep	Max. change of output signal at E_{max} during 30 min.	d_{cr}	< 0.0166	% C_n
Non-linearity ¹⁾	Deviation from best straight line through zero	d_{lin}	< 0.0166	% C_n
Hysteresis ¹⁾	Max. difference in LC output between loading and unloading	d_{hy}	< 0.0166	% C_n
Temperature effect (TK) on S_{min}	Max. change related to C_n of S_{min} per 10K in B_T	TK_{Smin}	< 0.0063 (11 kg and 22 kg) < 0.0056 (from 50 kg)	% C_n /10 K
TK on parameter ¹⁾	Max. change related to C_n of C per 10K in B_T	TK_C	< 0.0117	% C_n /10 K
Off-centre load error	In compliance with the technical data according to OIML R76		0.0233	% C_n
Input impedance	Between supply terminals	R_{LC}	1100 ± 50	Ω
Output impedance	Between measuring terminals	R_O	960 ± 50	Ω
Insulation impedance	Between measuring circuit and housing at 100 V _{DC}	R_{IS}	> 5000 × 10 ⁶	Ω
Nominal supply voltage range	To hold the specified performance	B_u	≤ 12	V _{DC}
Max. supply voltage	Continuous operation without damage	U_{max}	15	V _{DC}
Nominal ambient temp. range	To hold the specified performance	B_T	-10...+40	°C
Usable ambient temp. range	Continuous operation without damage	B_{Tu}	-30...+70	°C
Storage temperature range	Without electrical and mechanical stress	B_{Ti}	-50...+80	°C
Barometric pressure influence	Influence of barometric pressure on output		< 0.004	% C_n /kPa
Nominal deflection	Max. elastic deformation under maximum capacity	S_{nom}	< 0.25	mm
Cable length			3.5	m
Material	Stainless steel			
Max. platform size	In compliance with the technical data according to OIML R76		500 x 400	mm × mm
IP protection class	According to EN 60529		IP66/IP68/IP69	

¹⁾ Non-linearity (d_{lin}), hysteresis (d_{hy}) and parameter temperature effect (TK_C) are typical values. For OIML R60- and NTEP-approved load cells, the total of these values is within the permitted cumulative error limits.

Accuracy classes and minimum scale interval, v_{min}

	Maximum number of scale intervals, n_{max}	11 kg	22 kg	50 kg	100 kg	200 kg	Unit
OIML	3000	0.5	1.00	2.00	4.00	8.00	g
NTEP Class III Multiple	5000	0.5	1.00	2.00	4.00	8.00	g

Technical diagrams

Single Point load cell PR 55

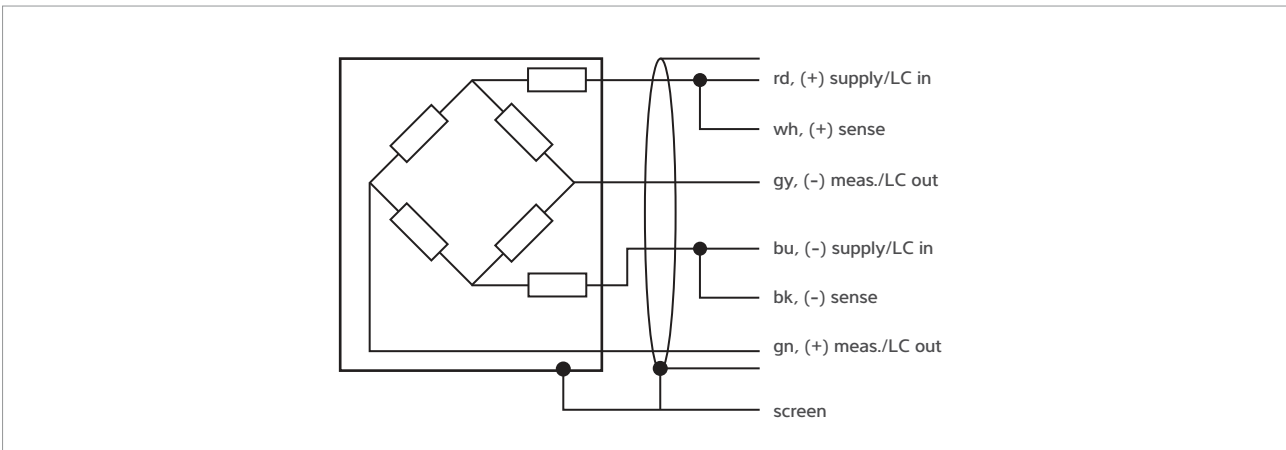
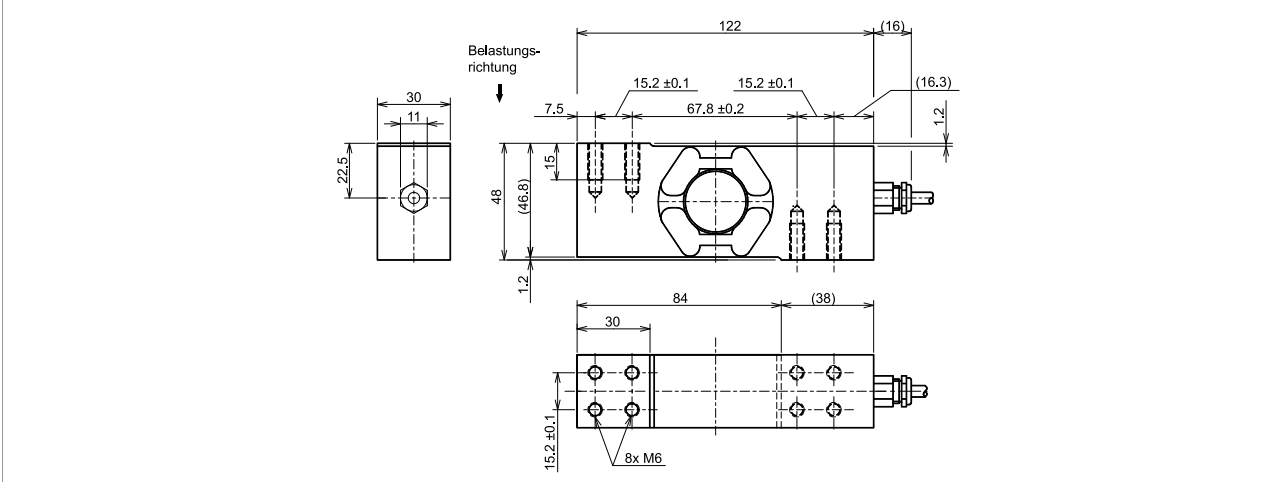

Circuit diagram

Ex approval



Explosion protection

Scope of validity:

Single Point load cell LC stainless steel

Single Point load cell PR 55 certificates			
Zone	Marking	Certificate number	For
0	II 1G Ex ia IIC T6/T4 Ga	BVS 21 ATEX E 023 X IECEX BVS 21.0024X	Only PR 5x/xx E
20	II 1D Ex ia IIIC T ₂₀₀ 165°C Da		
2	II 3G Ex ec IIC T6/T4 Gc		All PR 5x without E
21	II 2D Ex tb IIIC T110°C Db		

Ordering information

Single Point load cell PR 55	
Model	Order number
PR 55/11 kg C3MR	9409 255 07011
PR 55/22 kg C3MR	9409 255 07022
PR 55/50 kg C3MR	9409 255 07050
PR 55/100 kg C3MR	9409 255 07110
PR 55/200 kg C3MR	9409 255 07120
PR 55/11 kg C3MRE	9409 655 07011
PR 55/22 kg C3MRE	9409 655 07022
PR 55/50 kg C3MRE	9409 655 07050
PR 55/100 kg C3MRE	9409 655 07110
PR 55/200 kg C3MRE	9409 655 07120
PR 55/11 kg III 5000 S	9409 255 0C011
PR 55/22 kg III 5000 S	9409 255 0C022
PR 55/50 kg III 5000 S	9409 255 0C050
PR 55/100 kg III 5000 S	9409 255 0C110
PR 55/200 kg III 5000 S	9409 255 0C120

The products and solutions presented in this data sheet make major contributions in the following sectors:



Food and beverages



Chemistry



Agribusiness



Building materials



Machinery (OEM)

The technical data given serves as a product description only and should not be understood as guaranteed properties in the legal sense.

Specifications subject to change without notice.
Rev. 10/2023

Minebea Intec GmbH
Meiendorfer Strasse 205 A
22145 Hamburg, Germany
Phone +49.40.67960.303
sales.hh@minebea-intec.com
www.minebea-intec.com