

Truck scale load cell PR 6221, converter Connexx[®], mounting kits and junction boxes PR 6021

Premium components for vehicle weighing



German Quality



Digital Assistance
Technology

! Benefits

- Optimum reliability thanks to German Quality
- Precise measurement results for exact load billing
- Top fail-safe performance thanks to high lightning protection
- Optimum protection against water-logging, frost and de-icing salt
- Also available as a digital solution with converter Connexx[®]

The load cell PR 6221 was designed specifically for use in truck scales. Its outstanding precision and long product lifetime cut service and calibration costs, and help to reduce downtimes to a minimum. In combination with the converter Connexx[®], the PR 6221 becomes a digital solution.

Precise, fail-safe and extremely durable

- ! Both truck scale components are produced with great care in Germany. Their high quality guarantees **accurate results, a long product lifetime** and **reduces costs in the medium term.**
- ! **Maximum lightning protection:** with proper surge protection and potential equalisation, the PR 6221 can withstand voltages of up to at least 1,000 kV and currents of up to 100 kA without damage.
- ! The load cell guarantees **accurate measurement results** thanks to its special measuring element geometry.
- ! **Developed for the harshest ambient conditions,** the load cell can even withstand water immersion at a depth of 1.5 m for more than 10,000 hours.

The right solution for all of these applications:



Weighing



Filling and dosing



Fill quantity
control

Technical specifications

Technical data truck scale load cell PR 6221							
Designation	Description	Abbr.	C3*	C4*	C5*	C6*	Unit
Accuracy class			0.015	0.012	0.010	0.008	% E _{max}
Minimum dead load	Lowest limit of specified measuring range	E _{min}	0				% E _{max}
Maximum capacity	Highest limit of specified measuring range	E _{max}	12.5 to 75				t
Safe load limit	Maximum load possible without irreversible damage For E _{max} = 12.5 and 25 t For E _{max} = 20 t For E _{max} = 30 t For E _{max} ≥ 50 t	E _{lim}	37.5 40 60 75	37.5 40 60 75	... 40 60 75	... 40 60 75	t
Destructive load	Danger of mechanical destruction For E _{max} = 12.5 and 25 t For E _{max} = 20 t For E _{max} = 30 t For E _{max} ≥ 50 t	E _d	> 75 > 100 > 150 > 150	> 75 > 100 > 150 > 150	... > 100 > 150 > 150	... > 100 > 150 > 150	t
Minimum LC verification	Minimum load cell verification interval v _{min} = E _{max} /Y E _{max} = 12.5 t	Y	14,000 14,000	20,000 18,000	20,000 ...	20,000 ...	
Deadload output return	Factor for deadload output return after load (DR = 1/2 * E _{max} /Z) For E _{max} ≥ 50 t	Z	6,000 6,000	8,000 ⁽¹⁾ 6,000	8,000 ⁽¹⁾ 6,000	8,000 ⁽¹⁾ ...	
Rated output	Relative output at maximum capacity For E _{max} = 12.5 t For E _{max} = 20 t, 30 t For E _{max} = 25 t For E _{max} = 50 t For E _{max} = 60 t For E _{max} = 75 t	C _n	1.0 1.0 2.0 2.0 2.4 3.0	1.0 1.0 2.0 2.0 1.5 1.5	... 1.0 2.0 1.5 1.5 1.5	... 1.0 2.0 1.5 1.5 1.5	mV/V
Tolerance on rated output	Permissible deviation from rated output C _n	d _c	< 0.07				% C _n
Zero output signal	Load cell output signal under unloaded condition	S _{min}	0 ± 1.0				% C _n
Repeatability error	Max. change in load cell output for repeated loading	ε _R	< 0.005				% C _n
Creep	Max. change of output signal at E _{max} during 30 min.	d _{cr}	< 0.015	< 0.0125	< 0.010	< 0.008	% C _n
Non-linearity	Deviation from best straight line through zero	d _{Lin}	< 0.01				% C _n
Hysteresis	Max. difference in LC output between loading and unloading	d _{hy}	< 0.0165	< 0.0125	< 0.010	< 0.008	% C _n
Temperature effect on S _{min}	Max. change related to C _n of S _{min} per 10 K in B _T	TK _{Smin}	< 0.01	< 0.007	< 0.007	< 0.007	% C _n /10 K
Temperature effect on C	Max. change related to C _n of C per 10 K	TK _C	< 0.01	< 0.008	< 0.007	< 0.005	% C _n /10 K
Input impedance	Between supply terminals	R _{LC}	1,080 ± 10				Ω
Output impedance	Between measuring terminals For E _{max} ≤ 30 t For E _{max} = 50 t For E _{max} = 60 t For E _{max} = 75 t	R _O	1,010 ± 1 1,010 ± 1 1,010 ± 1 1,010 ± 1	1,010 ± 1 1,010 ± 1 635 ± 1 510 ± 1	1,010 ± 1 760 ± 1 635 ± 1 510 ± 1	1,010 ± 1 760 ± 1 635 ± 1 510 ± 1	Ω

Designation	Description	Abbr.	C3*	C4*	C5*	C6*	Unit
Accuracy class			0.015	0.012	0.010	0.008	% E _{max}
Insulation impedance	Between measuring circuit and housing at 100 U _{DC}	R _{IS}		> 5,000			MΩ
Insulation voltage	Between circuit and housing (PR 6221/ ..E only)			500			V
Nominal supply voltage range	To hold the specified performance	B _U		4 to 24			V
Max. supply voltage	Continuous operation without damage to PR 6221/ ..E	U _{max}		32 25			V
Nominal ambient temp. range	To hold the specified performance	B _T		-10 to +55			°C
Usable ambient temp. range	Continuous operation without damage	B _{TU}		-40 to +95			°C
Storage temperature range	Without electrical and mechanical stress	B _{TI}		-40 to +95			°C
Permissible eccentricity	Permissible displacement from nominal load line	S _{ex}		5			mm
Vibration resistance	Resistance against oscillations (IEC 68-2-6 Fc)			20 g, 100 h, 10 to 150 Hz			
Barometric pressure influence	Barometric pressure influence on S _{min}	PK _{Smin}		420			g/kPa
Nominal deflection	Max. elastic deformation under maximum capacity For E _{max} = 12.5 t For E _{max} = 20 t For E _{max} = 25 t For E _{max} = 30 t For E _{max} = 50 t For E _{max} = 60 t For E _{max} = 75 t	S _{nom}	0.2 0.4 0.5 0.5 0.8 0.9 1.1	0.2 0.4 0.5 0.5 0.8 0.9 1.1	... 0.4 0.5 0.5 0.8 0.9 1.1	... 0.4 0.5 0.5 0.8 0.9 1.1	mm
Material (housing)			1.4301 (DIN EN 10088-3)				
Protection class			- PR 6221: IP68** / IP69 - Connexx®: IP65 / IP68***				
Cables			TPE, colour: green, ø 5 mm, cable: 4×0.35 mm ² , length: 16 m PR 6221/ ..E TPE, colour: blue, ø 5 mm, cable: 4×0.35 mm ² , length: 20 m				
Bending radius			≥ 25 mm in case of fixed installation ≥ 75 mm in case of flexible installation				

Connexx®	Description	Abbr.	Temperature range	Unit
Nominal ambient temp. range	To hold the specified performance	B _T	-10...+40	°C
Usable ambient temp. range	Continuous operation without damage	B _{TU}	-30...+60	°C
Storage temperature range	Without electrical and mechanical stress	B _{TI}	-30...+70	°C

* As per OIML R60

** The load cell can be submerged at a water depth of 1.5 m for 10,000 hours.

*** The module can be submerged at a water depth of 1.5 m for 100 hours.

(1) Z = 8,000 for -10 °C ... +40°C, above +40°C Z = 6,000

Converter Connexx®



Fitted with the converter Connexx®, the load cell PR 6221 offers a comprehensive plus of possibilities:

- The digital version guarantees fast signalling times
- Thanks to the use of field bus communication, the cable junction box is no longer needed
- CANopen allows for extra-long communication paths of up to 200 m
- Weight values individually available for each load cell facilitate quick commissioning and make it easier to identify defective load cells

Dimensional drawings for load cells, mounting kits and junction boxes

Here you can select the right components for your truck scale load cell PR 6221. In addition to junction boxes and mounting kits, Minebea Intec offers a wide range of electronic weighing systems. Don't hesitate to contact us about an individual complete solution!

Truck scale load cell PR 6221 dimensions

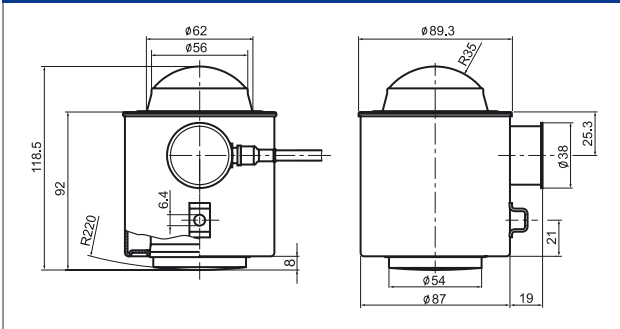

Truck scale load cell PR 6221

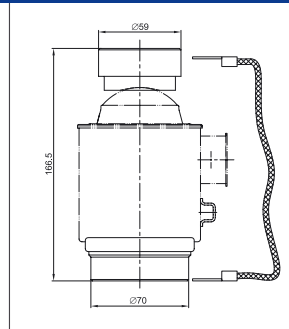

Truck scale load cell PR 6221 with standard load disc kit PR 6021/00N

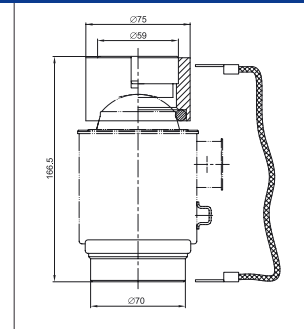

Truck scale load cell PR 6221 with turbo load disc .. /04N

Mounting kit PR 6021/01N, .. /03N, .. /05N and converter Connexx® dimensions

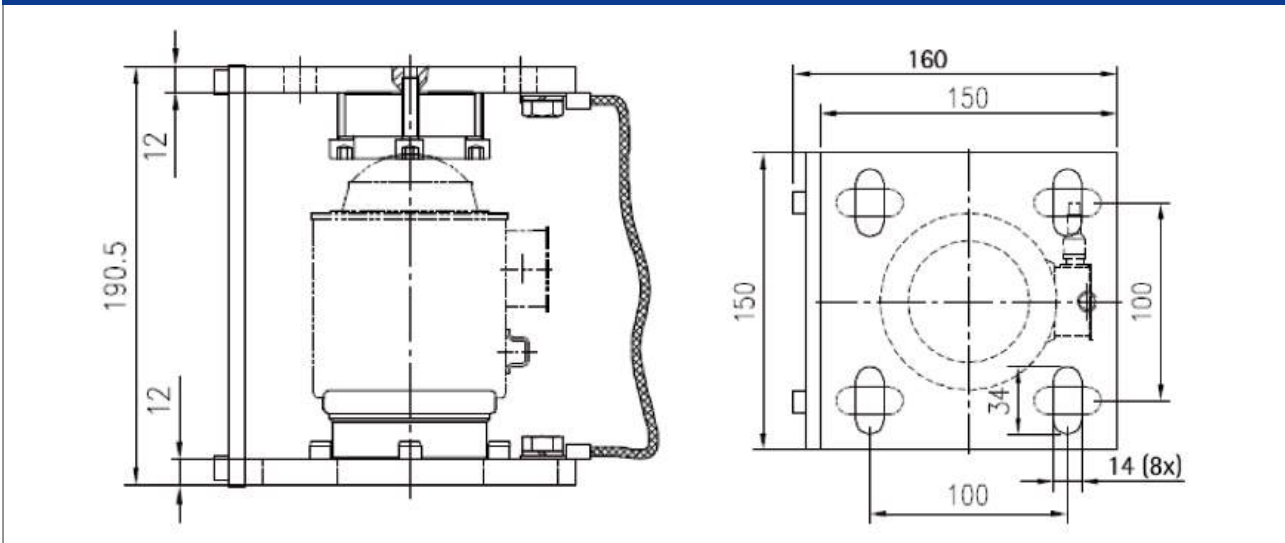

Truck scale load cell PR 6221 in mounting kit PR 6021/01N

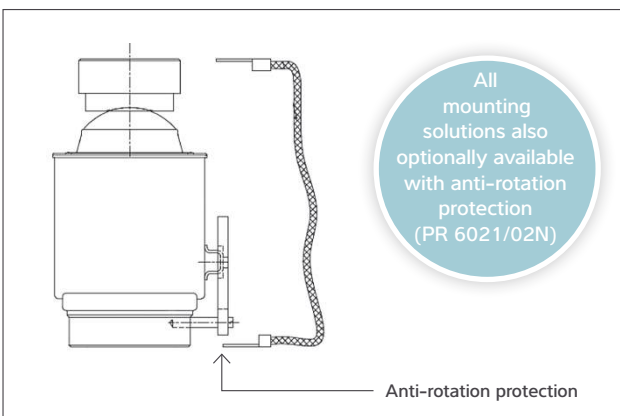

Anti-rotation protection

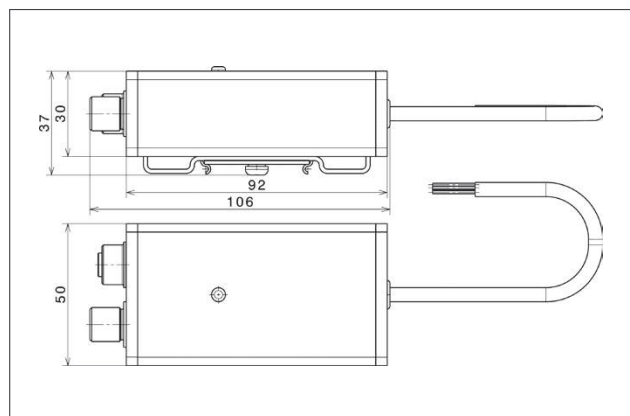

Converter Connexx®



Mounting kit PR 6021/03N

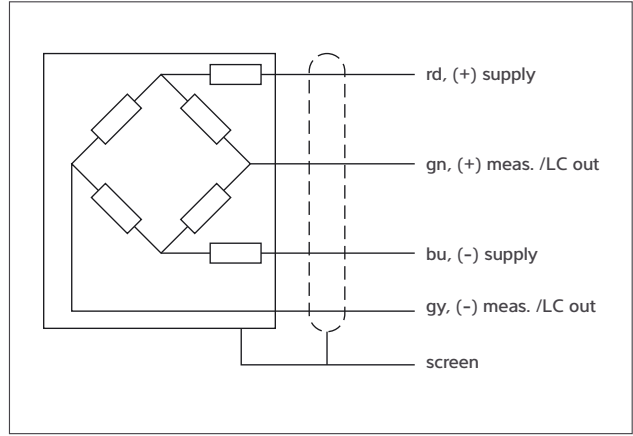

Circuit diagram



Easy Installation

Junction box dimensions

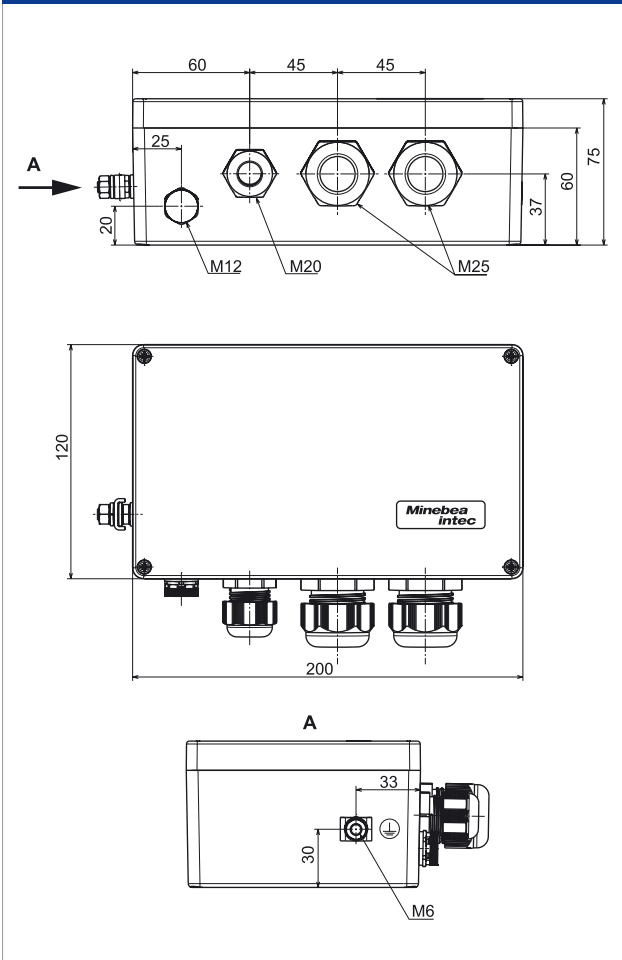

Junction box PR 6021/08 and PR 6021/18

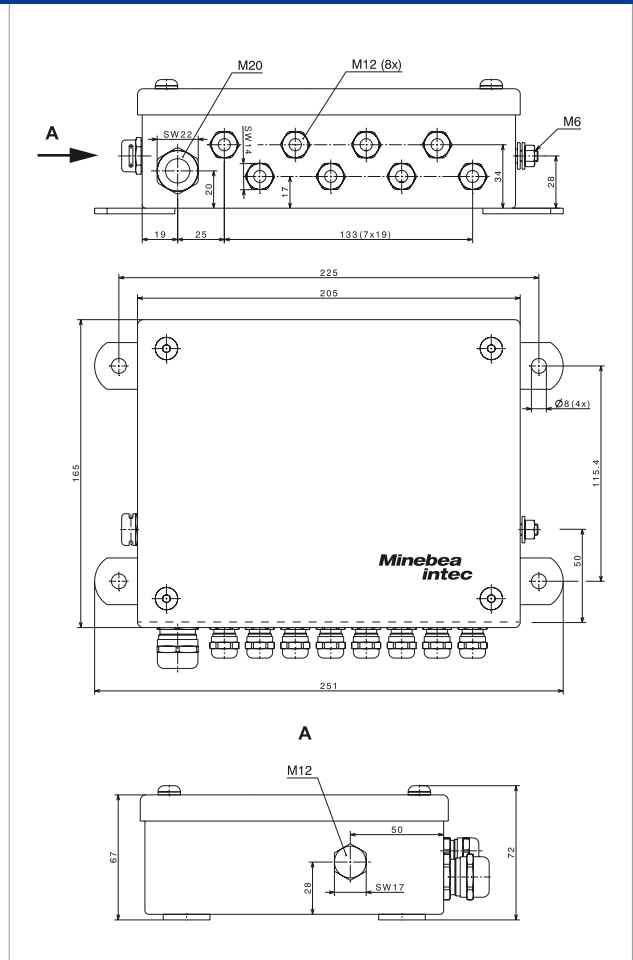

Junction box PR 6021/68S

High restoring force

When driving onto the truck scale, the forces applied result in a deflection of the load cell. The restoring force ensures that the load cell returns to its centred rest position as quickly as possible.

Maximum lightning protection

The truck scale load cells PR 6221 meet all requirements

- **Lightning surge current ($I_{\max} = 100 \text{ kA}$) $10 \mu\text{s}/350 \mu\text{s}$ (lightning protection class III) as per DIN EN 62475**
- **Lightning surge voltage ($U_{\max} = 1,000 \text{ kV}$) $1.2 \mu\text{s}/50 \mu\text{s}$ as per DIN EN/IEC 60060-1**

In the event of proper surge protection, potential equalisation, protection of the measuring cable and in conjunction with Minebea Intec junction boxes and indicators, the analogue load cells can withstand voltages of at least 1,000 kV and currents of up to 100 kA without damage.

Time savings with matched output

The output impedance (R_o) and parameter (C_n) of the load cells are within a tight tolerance range (= matched output) both individually and together. This means that there may possibly be no need for electrical corner correction and only mechanical height adjustment will be required.

Highest IP protection class and regional explosion protection certificate

Zone	Marking	Certificate no	Load cell*
0 and 1	II 1G Ex ia IIC T6 Ga Ex ia IIC T6 Ga	BVS 16 ATEX E 005 IECEX BVS 16.0005	PR 6221/..E
20 and 21	II 1D Ex ta IIIC T 160 °C Da Ex ta IIIC T 160 °C Da	TÜV 03 ATEX 2301X IECEX TUN 17.0025X	PR 6221 with add-on Atex zone 20/21
2	II 3G Ex nA IIC T6 Gc	Manufacturer's declaration	PR 6221 with add-on Atex zone 2/22
22	II 3D Ex tc IIIC T 85 °C Dc	Manufacturer's declaration	PR 6221 with add-on Atex zone 2/22
Class I, II, III Div. 1 and 2	IS CL I, II, III, DIV 1, GP A,B,C,D,E,F,G Entity - 4012 101 5688 NI CL I, II, III, DIV 2, GP A,B,C,D,E,F,G NIFW - 4012 101 5688 T4A Ta= -30 °C to 70 °C; T5 Ta= -30 °C to 55 °C	FM17US0276	PR 6221 with add-on FM
Class I, II, III Div. 1 and 2	IS CL I, II, III, DIV 1, GP A,B,C,D,E,F,G Entity - 4012 101 5688 NI CL I, II, III, DIV 2, GP A,B,C,D,E,F,G NIFW - 4012 101 5688 T4A Ta= -30 °C to 70 °C; T5 Ta= -30 °C to 55 °C	FM17CA0138	PR 6221 with add-on FM

* Please specify required explosion protection version when ordering.



Ordering information

Truck scale load cell PR 6221, OIML R60 accuracy class C3

Type	Order number
PR 6221/12.5T C3	940522103312
PR 6221/20TC3	940522103320
PR 6221/25TC3	940522103325
PR 6221/30TC3	940522103330
PR 6221/50TC3	940522103350
PR 6221/60TC3	940522103360
PR 6221/75TC3	940522103375

Truck scale load cell PR 6221, OIML R60 accuracy class C3, Ex version

Type	Order number
PR 6221/12,5T C3E	940562103312
PR 6221/20TC3E	940562103320
PR 6221/25TC3E	940562103325
PR 6221/30TC3E	940562103330
PR 6221/50TC3E	940562103350
PR 6221/60TC3E	940562103360
PR 6221/75TC3E	940562103375

Truck scale load cell PR 6221, OIML R60 accuracy class C4

Type	Order number
PR 6221/12.5T C4	940522104312
PR 6221/20TC4	940522104320
PR 6221/25TC4	940522104325
PR 6221/30TC4	940522104330
PR 6221/50TC4	940522104350
PR 6221/60TC4	940522104360
PR 6221/75TC4	940522104375

Truck scale load cell PR 6221, OIML R60 accuracy class C4, Ex version

Type	Order number
PR 6221/12,5T C4E	940562104312
PR 6221/20TC4E	940562104320
PR 6221/25TC4E	940562104325
PR 6221/30TC4E	940562104330
PR 6221/50TC4E	940562104350
PR 6221/60TC4E	940562104360
PR 6221/75TC4E	940562104375

Truck scale load cell PR 6221, OIML R60 accuracy class C5

Type	Order number
PR 6221/20TC5	940522105320
PR 6221/25TC5	940522105325
PR 6221/30TC5	940522105330
PR 6221/50TC5	940522105350
PR 6221/60TC5	940522105360
PR 6221/75TC5	940522105375

Truck scale load cell PR 6221, OIML R60 accuracy class C5, Ex version

Type	Order number
PR 6221/20TC5E	940562105320
PR 6221/25TC5E	940562105325
PR 6221/30TC5E	940562105330
PR 6221/50TC5E	940562105350
PR 6221/60TC5E	940562105360
PR 6221/75TC5E	940562105375

Truck scale load cell PR 6221, OIML R60 accuracy class C6

Type	Order number
PR 6221/20TC6	940522106320
PR 6221/25TC6	940522106325
PR 6221/30TC6	940522106330
PR 6221/50TC6	940522106350

Truck scale load cell PR 6221, OIML R60 accuracy class C6, Ex version

Type	Order number
PR 6221/20TC6E	940562106320
PR 6221/25TC6E	940562106325
PR 6221/30TC6E	940562106330

Truck scale load cell PR 6221, converter Connexx® – load cell accessories

Type	Description	Order number
PR 6221/Digital kit	The converter Connexx® can be ordered with all load cells in the series PR 6221, with the exception of Ex versions. When ordering, both order numbers need to be given.	940512100000

Additional information:

The converters Connexx® can be used with the indicator X3. To do this, the indicator X3 must be equipped with a CANopen interface card PR 5510/05 (940535510051). From 4 load cells, an external electrical supply with output 24 V_{DC}, 30 W is required in combination with the X3.

Truck scale load cell PR 6221, converter Connexx® – load cell accessories

Type	Description	Order number
PR 6152/10	Connection cable between Connexx® and X3 (10 m)	940536152101
PR 6152/25	Connection cable between Connexx® and X3 (25 m)	940536152251
PR 6152/40	Connection cable between Connexx® and X3 (40 m)	940536152401
PR 6153/98	Divided cable gland	940536153981
PR 6153/99	Terminating resistor for Connexx®, M12	940536153991
PR 6155/05	Connection cable between Connexx® and Connexx® (5 m)	940536155051
PR 6155/10	Connection cable between Connexx® and Connexx® (10 m)	940536155101

Mounting kits

Type	Description	Order number
PR 6021/00N	Load disc and base component, ground strap	940536021001
PR 6021/01N	Mounting kit (contains PR 6021/00N)	940536021011
PR 6021/02N	Upper and lower load disc with anti-rotation protection	940536021021
PR 6021/03N	Mounting kit incl. upper and lower load disc with anti-rotation protection	940536021031
PR 6021/04N	Upper (turbo) and lower load disc	940536021041
PR 6021/05N	Mounting kit incl. upper (turbo) and lower load disc	940536021051
PR 6021/06N	Upper (turbo) and lower load disc with anti-rotation protection	940536021061
PR 6021/07N	Mounting kit incl. upper (turbo) and lower load disc with anti-rotation protection	940536021071

Junction box

Type	Description	Order number
PR 6021/08	Junction box for truck scale with up to 8 load cells PR 6221	940536021084
PR 6021/18	Junction box with potentiometers for truck scale with up to 8 load cells PR 6221	940536021184
PR 6021/68S	Junction box for truck scale (Ex version), stainless steel with lightning protection	940536021684

The products and solutions presented in this data sheet make major contributions in the following sectors:



Food and beverages



Chemistry



Agribusiness



Building materials



Machinery (OEM)

The technical data given serves as a product description only and should not be understood as guaranteed properties in the legal sense.

Specifications subject to change without notice.
Rev. 03/2020

Minebea Intec GmbH
Meiendorfer Straße 205 A
22145 Hamburg, Germany
Phone +49.40.67960.303
sales.hh@minebea-intec.com
www.minebea-intec.com