

# Load cell PR 6241 and mounting kits PR 6041/PR 6043/PR 6044

For the precise weighing of process vessels



## ! Benefits

- Ultra-precise for high-accuracy dosing applications
- Wide load range
- Made of stainless steel
- Suitable mounting kits for perfect installation

*The PR 6241 series compression S-type load cells are specially designed for weighing small and medium process vessels and for high-precision dosing.*

## The solution for maximum accuracy in dosing and filling

- ① Maximum precision thanks to the combination of a "real" shearing force principle and pendulum support principle
- ① With a wide load range from 100 kg to 5 t, small and medium process vessels can be weighed
- ① Stainless steel ensures durability even under demanding conditions
- ① Mounting kits with integrated constrainer compensate for lateral forces such as those from mixers

# Technical specifications

Load cell PR 6241						
Parameter	Description	Abbr.	D1	C3	C6	Unit
Accuracy class			0.04	0.015	0.008	%E <sub>max</sub>
Minimum dead load	Lowest limit of specified measuring range	E <sub>min</sub>	0	0	0	%E <sub>max</sub>
Maximum capacity	Highest limit of specified measuring range	E <sub>max</sub>	See Ordering information table			kg
Safe load limit	Maximum load without irreversible damage	E <sub>lim</sub>	150	150	150	%E <sub>max</sub>
Destructive load	Danger of mechanical destruction	E <sub>d</sub>	> 300	> 300	> 300	%E <sub>max</sub>
Minimum load cell verification interval (OIML) For NTEP, see separate table	Minimum load cell verification interval, V <sub>min</sub> = E <sub>max</sub> /Y	Y	5,000	14,000	20,000	
Deadload output return	Factor for deadload output return after load (DR=1/2*E <sub>max</sub> /Z)	Z	1,000	3,000	8,000	
Rated output	Relative output at maximum capacity	C <sub>n</sub>	2	2	2	mV/V
Tolerance on rated output	Permissible deviation from rated output	d <sub>c</sub>	<0.25	<0.07	<0.07	%C <sub>n</sub>
Zero output signal	Load cell output signal under unloaded condition	S <sub>min</sub>	0±1.0	0±1.0	0±1.0	%C <sub>n</sub>
Reproducibility	Max. change in load cell output for repeated loading	e <sub>R</sub>	<0.01	<0.005	<0.005	%C <sub>n</sub>
Creep	Max. change of output signal at E <sub>max</sub> for 30 min.	d <sub>cr</sub>	<0.03	<0.015	<0.008	%C <sub>n</sub>
Non-linearity <sup>1)</sup>	Max. deviation from best straight line through zero	d <sub>lin</sub>	<0.03	<0.01	<0.01	%C <sub>n</sub>
Hysteresis <sup>1)</sup>	Max. difference in LC output between loading and unloading	d <sub>hy</sub>	<0.04	<0.015	<0.008	%C <sub>n</sub>
Temperature effect on S <sub>min</sub>	Max. change of S <sub>min</sub> in B <sub>T</sub>	TK <sub>Smin</sub>	<0.028	<0.01	<0.007	%C <sub>n</sub> /10 K
Temperature effect on C <sup>1)</sup>	Max. change of C in B <sub>T</sub>	TK <sub>C</sub>	<0.03	<0.01	<0.005	%C <sub>n</sub> /10 K
Input impedance	Between supply terminals	R <sub>LC</sub>	650 ± 6	650 ± 6	650 ± 6	Ω
Output impedance	Between measuring terminals	R <sub>O</sub>	610 ± 1	610 ± 0.5	610 ± 0.5	Ω
Insulation impedance	Between measuring circuit and housing at 100 V <sub>DC</sub>	R <sub>IS</sub>	> 5,000 × 10 <sup>6</sup>	> 5,000 × 10 <sup>6</sup>	> 5,000 × 10 <sup>6</sup>	Ω
Insulation voltage	Between circuit and housing (PR 6241/..E only)		500	500	500	V
Recommended supply voltage	To hold the specified performance	B <sub>u</sub>	4...24	4...24	4...24	V <sub>DC</sub>
Max. supply voltage	Permissible for continuous operation without damage	U <sub>max</sub>	28/(EX versions: 25)			V <sub>DC</sub>
Nominal ambient temp. range	To hold the specified performance	B <sub>T</sub>	-10...+55	-10...+55	-10...+55	°C
Usable ambient temp. range	Permissible for continuous operation without damage	B <sub>Tu</sub>	-40...+95	-40...+95	-40...+95	°C
Storage temperature range	Without electrical and mechanical stress	B <sub>Ti</sub>	-40...+95	-40...+95	-40...+95	°C
Permissible eccentricity	Permissible displacement from nominal load line	S <sub>ex</sub>	5	5	5	mm
Vibration resistance	Resistance against oscillations (IEC 68-2-6 Fc)		20 g, 100 h, 10...150 Hz			
Barometric pressure influence	Influence of barometric pressure on output	PK <sub>Smin</sub>	<0.005	<0.0025	<0.0025	%C <sub>n</sub> /kPa
Nominal deflection	Max. elastic deformation under maximum capacity	S <sub>nom</sub>	< 0.3 for E <sub>max</sub> < 5 t / < 0.5 for E <sub>max</sub> = 5 t			mm
Material (sensor)	Stainless steel 1.4542					
Protection class	PR 6241: IP68*/IP69 Connexx®: IP65/IP68**					
Cable	Length: 5 m Diameter: 5 mm Cross section: 4 × 0.35 mm <sup>2</sup> Material cable sheath: TPE					
Bending radius	≥ 25 mm at fixed installation ≥ 75 mm at flexible installation					
Connexx®						
Nominal ambient temp. range	To hold the specified performance	B <sub>T</sub>	-10...+40			°C
Usable temperature range	Permissible for continuous operation without damage	B <sub>Tu</sub>	-30...+60			°C
Storage temperature range	Without electrical and mechanical stress	B <sub>Ti</sub>	-30...+70			°C

\* The load cell can be submerged in water at a depth of 1.5 m for 10,000 hours.

\*\* The module can be submerged in water at a depth of 1.5 m for 100 hours.

<sup>1)</sup> The data for Non-linearity, hysteresis and TKC are typical values. For OIML R60 or NTEP approved load cells the sum of these values is within the permissible cumulative error

## NTEP classification PR 6241

NTEP			NTEP minimum load cell verification interval, $v_{min}$								
Maximum capacity	with OIML class	divisions $n_{max}$	100 kg	200 kg	300 kg	500 kg	1 t	2 t	3 t	5 t	Unit
Class III Multiple	D1	2,000	20	40	60	100	200	400	600	1,000	g
Class III Multiple	C3	5,000	--	14.3	21	36	71	143	214	357	g
Class III Multiple	C6	8,000	--	10	15	25	50	100	150	--	g
Class III L Multiple	D1	5,000	6.7	13.3	20	33	67	133	200	333	g
Class III L Multiple	C3	10,000	--	5	7.1	12	24	48	71	119	g
Class III L Multiple	C6	10,000	--	3	5	8	17	33	50	--	g

## Mounting kits PR 6041/PR 6043/PR 6044

Maximum capacity of load cell PR 6241	Mounting kit/ accessories	Material	Description/ comments	Mounting screws	Installation height (mm)	Max. permissible horizontal force (kN)	Horizontal destructive force [kN]	Max. permissible lift-off force [kN]	Max. permissible vertical load without load cell
100 kg–500 kg	PR 6041/04N		Elastomeric bearing	M12	53	/	/	/	/
100 kg–2 t	PR 6041/30N	Electrogalvanised steel S235, passivated and sealed	Plate mounting kit	M8-5.8	92	/	/	/	/
	PR 6041/30S	Stainless steel 1.4301 (AISI 304)	Plate mounting kit	M8-A2-70		/	/	/	/
	PR 6043/30N	Electrogalvanised steel S235, passivated and sealed	MiniFLEXLOCK	M8-8.8		6	20	/	2 t
	PR 6043/30S	Stainless steel 1.4301 (AISI 304)	MiniFLEXLOCK	M8-A2-70		6	20	/	2 t
	PR 6044/00S		Plate mounting kit	M8-A2-70		/	/	10	2 t
	PR 6044/10S		MaxiFLEXLOCK	M8-A2-70		6	20	10	2 t
	PR 6041/51S		Platform base	/		44	/	/	/
	PR 6043/31S		Load disc kit	/	/	/	/	/	/
3 t–5 t	PR 6041/40N	Electrogalvanised steel S235, passivated and sealed	Plate mounting kit	M12-5.8	130	/	/	/	/
	PR 6041/40S	Stainless steel 1.4301 (AISI 304)	Plate mounting kit	M12-A2-70		/	/	/	/
	PR 6043/40N	Electrogalvanised steel S235, passivated and sealed	MiniFLEXLOCK	M12-8.8		18	50	/	5 t
	PR 6043/40S	Stainless steel 1.4301 (AISI 304)	MiniFLEXLOCK	M12-A2-70		18	50	/	5 t
	PR 6044/01S		Plate mounting kit	M12-A2-70		/	/	20	5 t
	PR 6044/11S		MaxiFLEXLOCK	M12-A2-70		18	50	20	5 t



Fitted with the converter Connexx®, the load cell PR 6241 offers a whole host of possibilities:

- The digital version guarantees fast signalling times for reliable dosing processes.
- Thanks to the use of field bus communication, the cable junction box is no longer needed.
- The standard interface CANopen ensures straightforward installation and calibration.
- CANopen allows for extra-long communication paths of up to 200 m.
- Weight values can also be generated individually – per load cell – meaning that defective load cells can be identified more easily.

## Technical diagrams

### Compression S-type load cell PR 6241

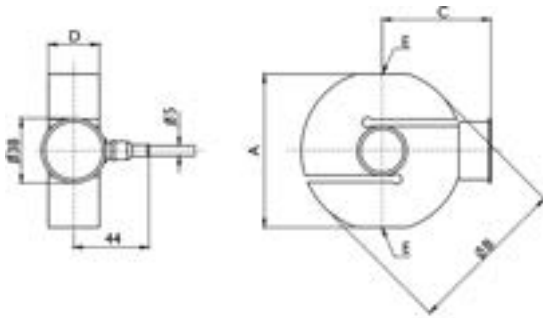

Model	A [mm]	B [mm]	C [mm]	D [mm]	E [mm]
PR 6241/12...52	60	65	50	23	M12
PR 6241/13...23	60	65	50	30	M12
PR 6241/33	90	95	64	30	M20 × 1.5
PR 6241/53	90	95	64	35	M20 × 1.5

### Converter Connex<sup>®</sup>

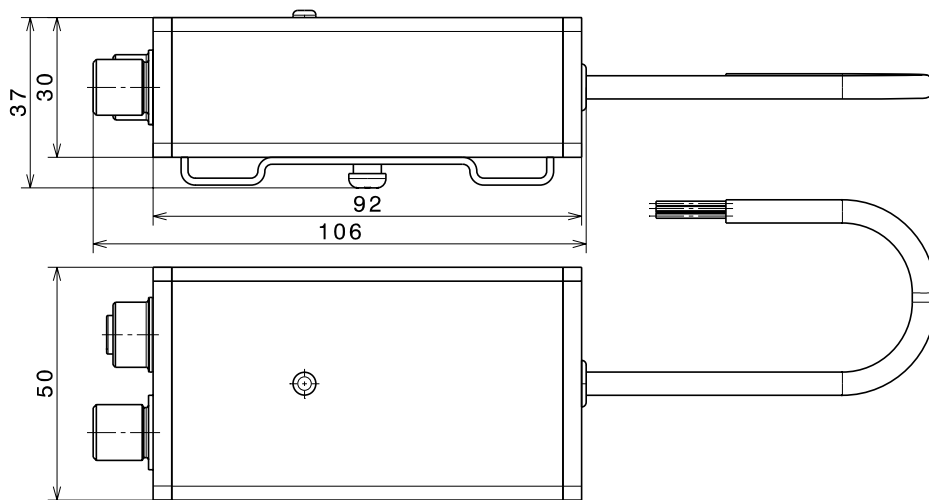

Converter Connex<sup>®</sup>

### Mounting kits PR 6041/PR 6043/PR 6044

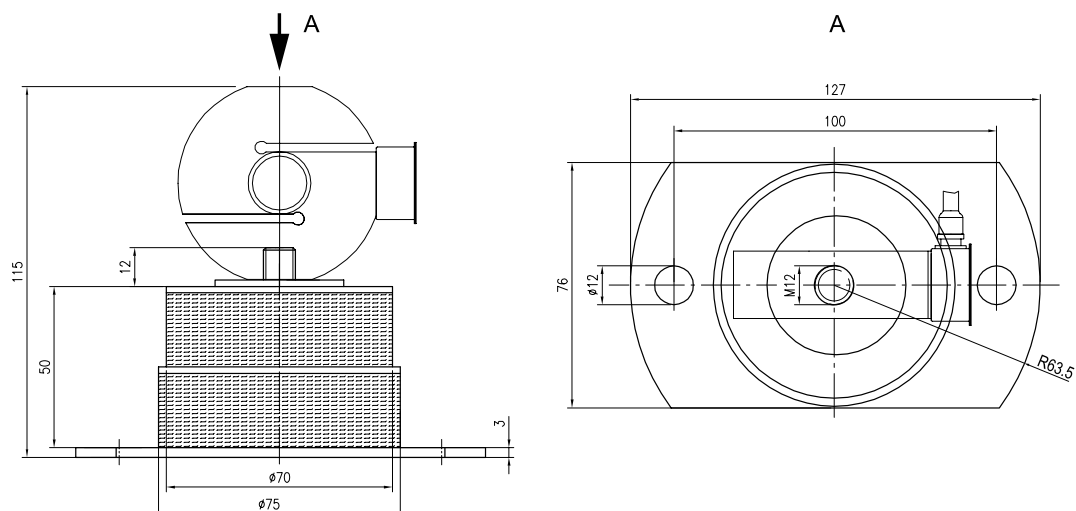

Elastomeric bearing PR 6041/04N

All dimensions in mm

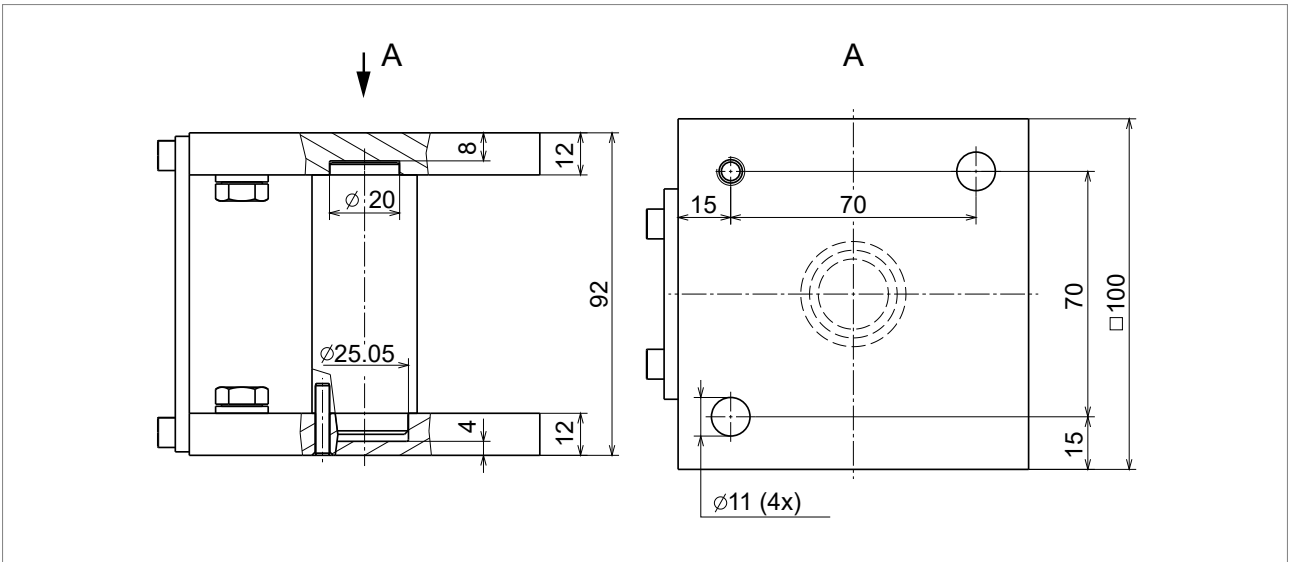

Plate mounting kit PR 6041/30N+S

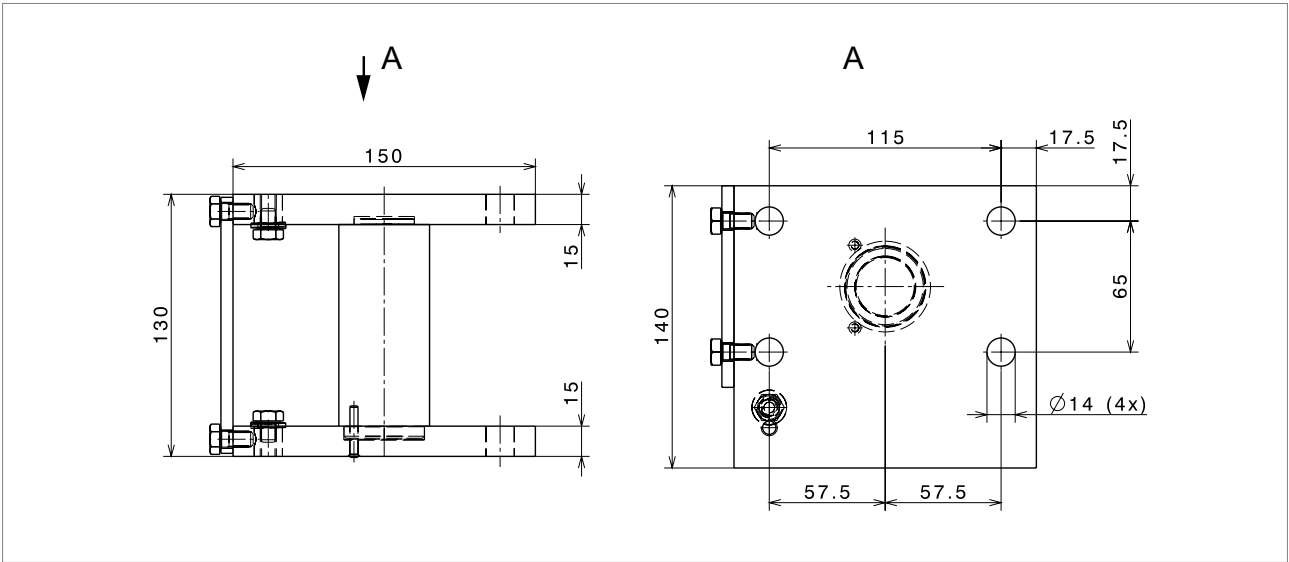
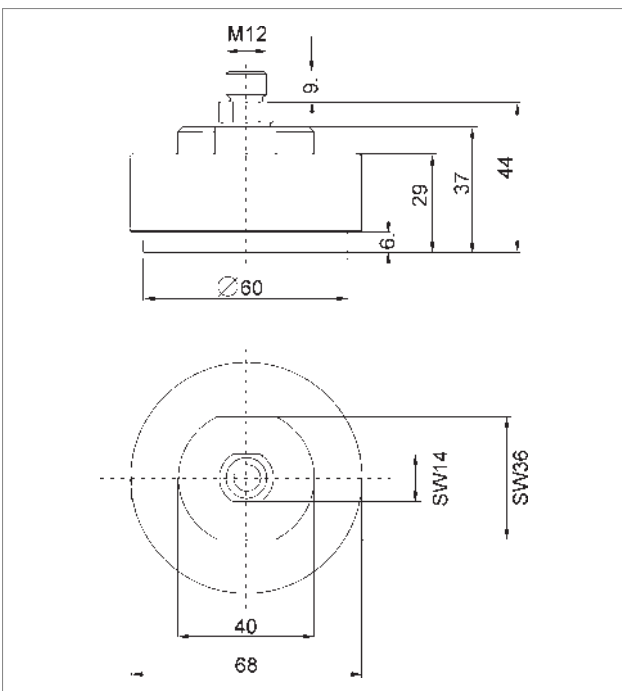
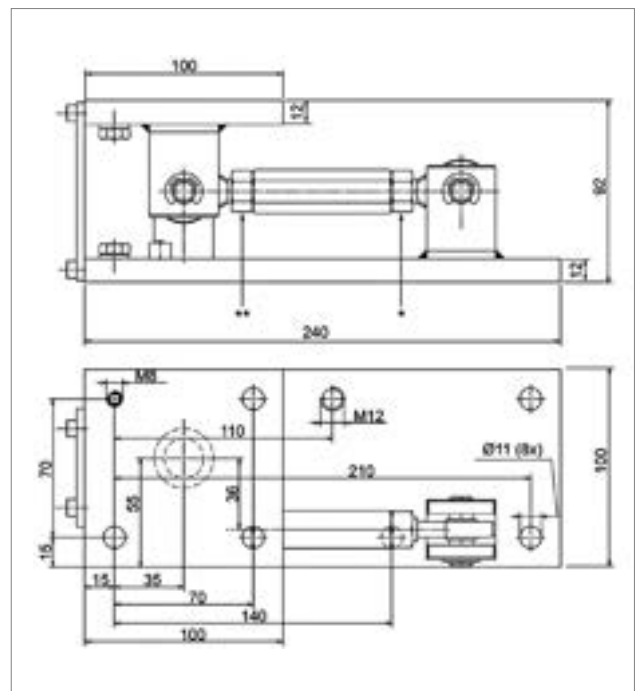

Plate mounting kit PR 6041/40N+S



Platform base PR 6041/51



MiniFLEXLOCK PR 6043/30N+S

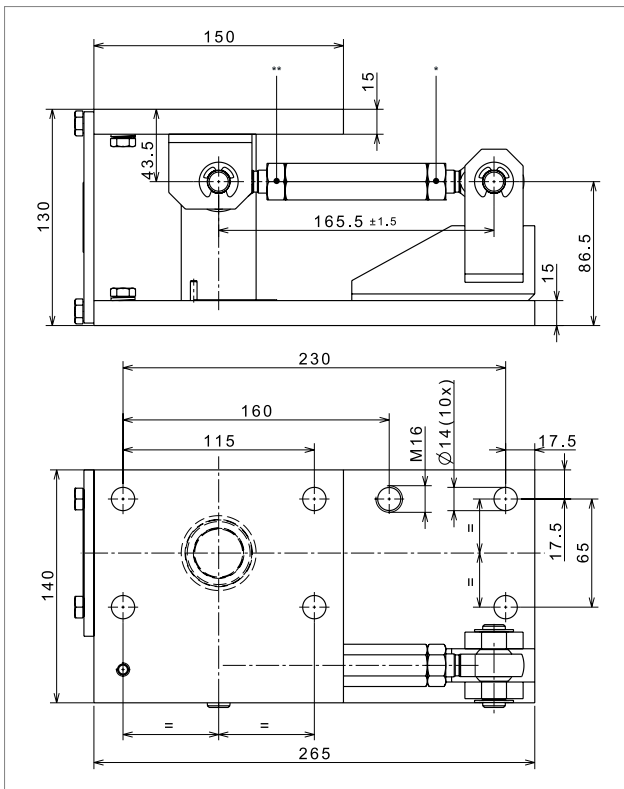

MiniFLEXLOCK PR 6043/40N+S

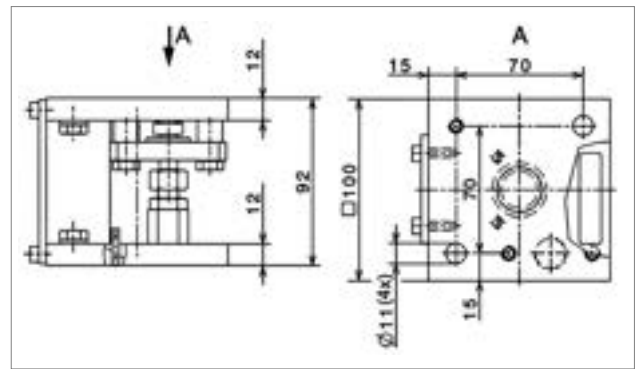

Plate mounting kit PR 6044/00S

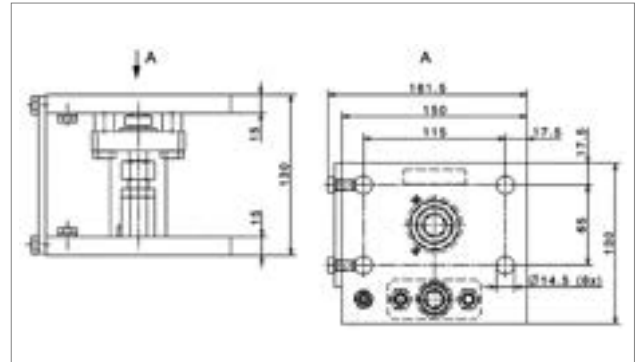
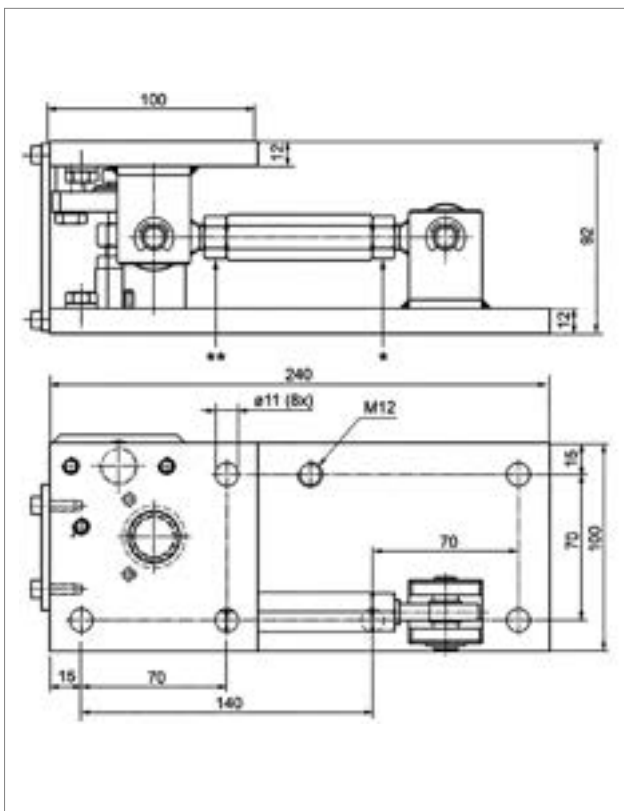
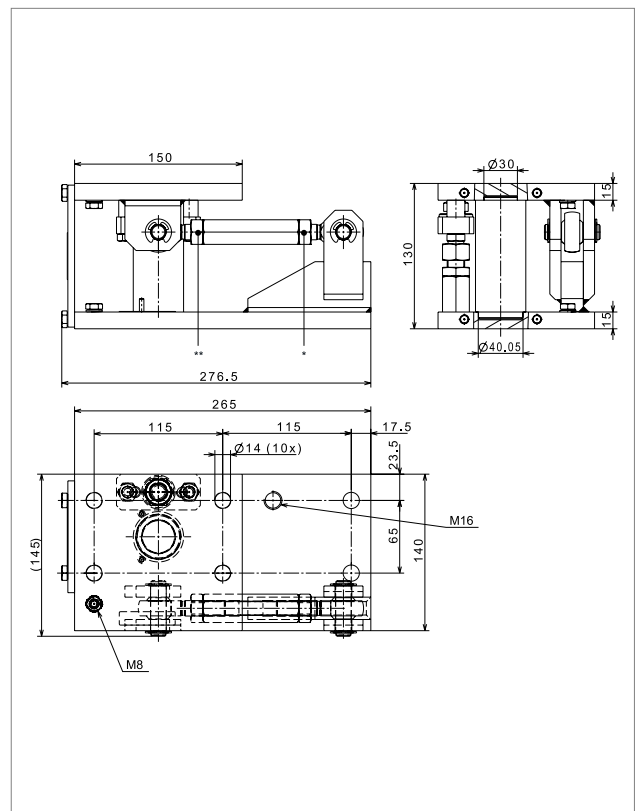

Plate mounting kit PR 6044/01S



MaxiFLEXLOCK PR 6044/10S



MaxiFLEXLOCK PR 6044/11S

# Ex approval

**Scope of validity:**  
PR 6241 (100 kg...5 t)



Certificates for compression S-type load cell PR 6241			
Zone	Labelling	Certificate number	For
0 and 1	II 1G Ex ia IIC T6 Ga Ex ia IIC T6 Ga 0Ex ia IIC T6 (")	BVS 16 ATEX E 005 IECEX BVS 16.0005	PR 6241/..E only
20 and 21	II 1D Ex ta IIIC T160°C Da Ex ta IIIC T160°C Da Ex ta IIIC T160°C X (")	TÜV 03 ATEX 2301X IECEX TUN 17.0025X	PR 6241 with add-on ATEX-Zone 20/21
2	II 3G Ex nA IIC T6 Gc	Manufacturer's declaration	PR 6241 with add-on ATEX-Zone 2
22	II 3D Ex tc IIIC T85 °C Dc	Manufacturer's declaration	PR 6241 with add-on ATEX-Zone 22
FMus	IS CL I, II, III, DIV 1, GP A, B, C, D, E, F, G Entity – 4012 101 5688 NI CL I, II, III, DIV 2, GP A, B, C, D, E, F, G NIFW – 4012 101 5688 T4A Ta= -30 °C to 70 °C; T5 Ta= -30 °C to 55 °C	FM17USO276	PR 6241 with add-on FM
FMca	IS CL I, II, III, DIV 1, GP A, B, C, D, E, F, G Entity – 4012 101 5688 NI CL I, II, III, DIV 2, GP A, B, C, D, E, F, G NIFW – 4012 101 5688 T4A Ta= -30 °C to 70 °C; T5 Ta= -30 °C to 55 °C	FM17CA0138	PR 6241 with add-on FM

## Ordering information

Compression S-type load cells OIML R60, accuracy class D1 = 0.04%		
Type	Maximum capacity	Order number
PR 6241/12D1	100 kg	940526241121
PR 6241/22D1	200 kg	940526241221
PR 6241/32D1	300 kg	940526241321
PR 6241/52D1	500 kg	940526241521
PR 6241/13D1	1 t	940526241131
PR 6241/23D1	2 t	940526241231
PR 6241/33D1	3 t	940526241331
PR 6241/53D1	5 t	940526241531

Compression S-type load cells OIML R60, accuracy class D1 = 0.04%, ex-version		
Type	Maximum capacity	Order number
PR 6241/12D1E	100 kg	940566241121
PR 6241/22D1E	200 kg	940566241221
PR 6241/32D1E	300 kg	940566241321
PR 6241/52D1E	500 kg	940566241521
PR 6241/13D1E	1 t	940566241131
PR 6241/23D1E	2 t	940566241231
PR 6241/33D1E	3 t	940566241331
PR 6241/53D1E	5 t	940566241531

Precision compression S-type load cells OIML R60, accuracy class C3 = 0.015%		
Type	Maximum capacity	Order number
PR 6241/22C3	200 kg	940526241227
PR 6241/32C3	300 kg	940526241327
PR 6241/52C3	500 kg	940526241527
PR 6241/13C3	1 t	940526241137
PR 6241/23C3	2 t	940526241237
PR 6241/33C3	3 t	940526241337
PR 6241/53C3	5 t	940526241537

Precision compression S-type load cells OIML R60, accuracy class C3 = 0.015%, ex-version		
Type	Maximum capacity	Order number
PR 6241/22C3E	200 kg	940566241227
PR 6241/32C3E	300 kg	940566241327
PR 6241/52C3E	500 kg	940566241527
PR 6241/13C3E	1 t	940566241137
PR 6241/23C3E	2 t	940566241237
PR 6241/33C3E	3 t	940566241337
PR 6241/53C3E	5 t	940566241537

**Precision compression S-type load cells OIML R60, accuracy class C6 = 0.008%**

Type	Maximum capacity	Order number
PR 6241/22C6	200 kg	940526241228
PR 6241/32C6	300 kg	940526241328
PR 6241/52C6	500 kg	940526241528
PR 6241/13C6	1 t	940526241138
PR 6241/23C6	2 t	940526241238
PR 6241/33C6	3 t	940526241338

**Precision compression S-type load cells OIML R60, accuracy class C6 = 0.008%, ex-version**

Type	Maximum capacity	Order number
PR 6241/22C6E	200 kg	940566241228
PR 6241/32C6E	300 kg	940566241328
PR 6241/52C6E	500 kg	940566241528
PR 6241/13C6E	1 t	940566241138
PR 6241/23C6E	2 t	940566241238
PR 6241/33C6E	3 t	940566241338

**Precision compression S-type load cells OIML R60, converter Connexx®**

Type	Description	Order number
PR 6241/DIGITAL KIT	The converter Connexx® can only be ordered with the above-mentioned load cells from the PR 6241 series. When ordering, both order numbers need to be given.	940514100000

**Additional information:**

The converters Connexx® can be used with the Indicator X3.

To do this, the indicator X3 must be equipped with a CANopen interface card PR 5510/05 (940535510051).

**Precision compression S-type load cells OIML R60, converter Connexx® – application sets**

Type	Description	Order number
PR 6154/03	Application set for 3 load cells. Includes: 2 × PR 6155/05, 1 × PR 6152/25, 1 × PR 6153/99	940536154031
PR 6154/04	Application set for 4 load cells. Includes: 3 × PR 6155/05, 1 × PR 6152/25, 1 × PR 6153/99	940536154041

**Precision compression S-type load cells OIML R60, converter Connexx® – load cell accessories**

Type	Description	Order number
PR 6152/10	Connection cable between Connexx® and X3 (10 m)	940536152101
PR 6152/25	Connection cable between Connexx® and X3 (25 m)	940536152251
PR 6152/40	Connection cable between Connexx® and X3 (40 m)	940536152401
PR 6153/98	Divided cable gland	940536153981
PR 6153/99	Terminal resistor for Connexx®, M12	940536153991
PR 6155/05	Connection cable between Connexx® and Connexx® (5 m)	940536155051
PR 6155/10	Connection cable between Connexx® and Connexx® (10 m)	940536155101

### Mounting kits PR 6041 without constrainer

Type	Order number
PR 6041/04N	940536041041
PR 6041/30N	940536041301
PR 6041/30S	940536041302
PR 6041/40N	940536041401
PR 6041/40S	940536041402
PR 6041/51S	940536041512

### Mounting kits PR 6043 – MiniFLEXLOCK with integrated constrainer

Type	Order number
PR 6043/30N	940536043301
PR 6043/30S	940536043302
PR 6043/40N	940536043401
PR 6043/40S	940536043402

### Mounting kits PR 6044 – MaxiFLEXLOCK with additional functions

Type	Order number
PR 6044/00S	940536044002
PR 6044/10S	940536044102
PR 6044/01S	940536044012
PR 6044/11S	940536044112

### Mounting kits PR 6043 – load discs

Type	Order number
PR 6043/31S	940536043312

The products and solutions presented in this data sheet make major contributions in the following sectors:



Food and beverages



Pharmaceutical



Chemistry



Cosmetics



Machinery (OEM)

The technical data given serves as a product description only and should not be understood as guaranteed properties in the legal sense.

Specifications subject to change without notice.  
Rev. 01/2026

Minebea Intec GmbH  
Meiendorfer Straße 205 A  
22145 Hamburg, Germany  
Phone +49.40.67960.303  
sales.hh@minebea-intec.com  
www.minebea-intec.com