



sartorius

PR 6207

Beam Type Load Cell



10kg... 200kg Type D1/C3

- Easy to install
- Full stainless steel construction
- Wide temperature range
- Resistant against vibration
- Hermetically sealed, IP 67
- Compatible with other sources

Product Profile

The load cell PR6207 is specially designed for tank and hopper weighing and for the use in platform scales or belt weighers.

The design principle of the mounting kit PR6007 will counterbalance movements arising from mechanical and thermal expansion or contraction of its supporting structure.

A particular design characteristic is that the sensor is manufactured out of stainless steel (1.4122) and the membrane is made out of 1.4541.

Therefore the line is distinguished with high measurement accuracy and high repeatability as well as stability and reliability. This is the sound basis for maintenance free work and years without any further adjustments.

The hermetically sealed sensor allows to use the device even under extreme operation conditions.

The entire measurement chain can be calibrated without using a reference weight. Due to "matched output" technology, a damaged load cell can be exchanged without the need of re-calibration. This saves a tremendous amount of time during commissioning and in case of necessary replacement.

Load cell construction

Double bending beam, all stainless steel, hermetically sealed, welded, filled with inert gas.

Protection

IP 67, DIN 40 050. The load cell can be submerged in water to a depth of 1.5m for 100hrs.

Bending radius

fixed installation $r \geq 60\text{mm}$
with repeated bending $r \geq 150\text{mm}$

Material Body

Body 1.4122 (DIN 17440)
Bellow 1.4541 (DIN 17440)

Cable

robust, flexible, screened $4 \times 0.34\text{mm}^2$
sheath: grey, PVC
diameter: $D = 5.4\text{mm}$
length: 3m

Technical Data

			D1	C3	
Accuracy class			0.05	0.017	% E_{\max}
Minimum dead load	lowest limit of specified measuring range	E_{\min}	0	0	% E_{\max}
Maximum capacity	highest limit of specified measuring range	E_{\max}	s. table	s. table	
Max. side load (x)	highest limit of static load in x-direction	L_{lx}	200	200	% E_{\max}
Max. side load (z)	highest limit of static load in z-direction	L_{lz}	200	200	% E_{\max}
Min. LC verification interval	minimum load cell verification interval, $v_{\min} = E_{\max} / Y$	Y	2.778	11.111	
Rated output	relative output at nominal load	C_n	2	2	mV/V
Tolerance on rated output	permissible deviation from rated output	d_c	< (+1.0 - 0.1)	< 0.1	% C_n
Zero output signal	load cell output signal under unloaded condition	S_{\min}	< 1.0	< 1.0	% C_n
Repeatability error	max. change in load cell output for repeated loading	ϵ_R	< 0.03	< 0.01	% C_n
Creep, during 30min.	max. change in load cell output under nominal load	d_{cr}	< 0.05	< 0.017	% C_n
Non-Linearity	max. deviation from best straight line through zero	d_{lin}	< 0.05	< 0.017	% C_n
Hysteresis	max. difference in load cell output when loading from	d_{hy}	< 0.05	< 0.018	% C_n
Temperature effect on S_{\min}	max. change of $S_{\min}/10\text{K}$ over B_T	$TK_{S_{\min}}$	< 0.05	< 0.013	% $C_n/10\text{K}$
Temperature effect on C	max. change of $C/10\text{K}$ over B_T	TK_c	< 0.05	< 0.008	% $C_n/10\text{K}$
Input impedance	between supply terminals	R_{IC}	350... 480	350... 480	Ω
Output impedance	between measuring terminals	R_o	356 ± 0.2	356 ± 0.12	Ω
Insulation impedance	between measuring circuit and housing at $100V_{\text{DC}}$	R_{IS}	$> 5.000 \times 10^6$	$> 5.000 \times 10^6$	Ω
Recommended supply voltage	to hold the specified performance	B_u	4... 12	4... 12	V
Max. supply voltage	permissible for continuous operation without damage	U_{\max}	18	18	V
Nominal ambient temp. range	to hold the specified performance	B_T	-10... +70	-10... +70	$^{\circ}\text{C}$
Usable ambient temp. range	permissible for continuous operation without damage	B_{tu}	-30... +70	-30... +70	$^{\circ}\text{C}$
Storage temperature range	Transportation and storage	B_{tl}	-50... +85	-50... +85	$^{\circ}\text{C}$
Vibration resistance	resistance against oscillation (IEC 68-2-6 Fc)		10g, 100h, 10... 150Hz	10g, 100h, 10... 150Hz	
Nominal deflection	max. elastic deformation under nominal load	S_{nom}	0.3 - 0.4	0.3 - 0.4	mm

Definitions acc. to VDI / VDE 2637

The technical data given here serve only as a product description and must not be interpreted as guaranteed characteristics in the legal sense.

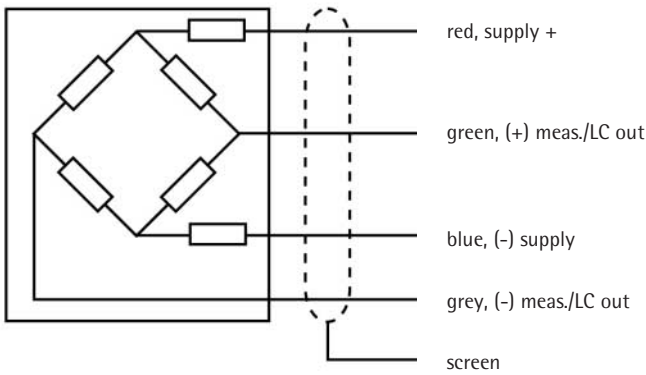
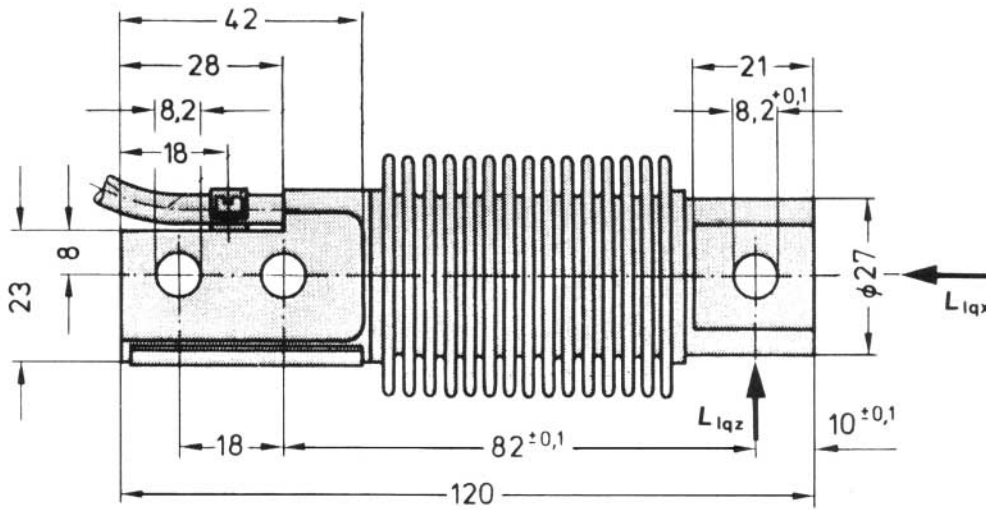
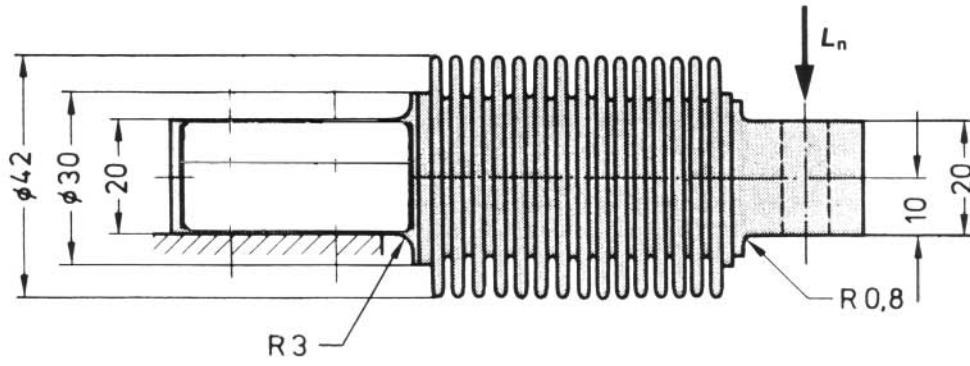

Order information

Type	Nominal Load E_{max}	Version	Max. usable load (in % of E_{max})	Destructive load (in % of E_{max})	Packing	Weight gross/net
PR6207/11	10kg	D1/C3	150	> 300	280 x 160 x 90mm	0,9kg/0,5kg
PR6207/21	20kg	D1/C3	150	> 300	280 x 160 x 90mm	0,9kg/0,5kg
PR6207/51	50kg	D1/C3	150	> 300	280 x 160 x 90mm	0,9kg/0,5kg
PR6207/12	100kg	D1/C3	150	> 300	280 x 160 x 90mm	0,9kg/0,5kg
PR6207/22	200kg	D1/C3	150	> 300	280 x 160 x 90mm	0,9kg/0,5kg

Further options

Type	Description		Dimensions	Order number
PR6130/08	Plastic Cable junction box	for all industrial applications, max. 8 load cells	250 x 180 x 90mm	9405 361 30081
PR6130/04	Cable junction box	Aluminium, grey painted, IP 68, for all industrial applications, max. 4 load cells	175 x 80 x 57mm	9405 361 30041
PR6130/64	Stainless steel cable junction box	material stainless steel 1.4301, IP 68, IP 69K, for all industrial, intrinsically safe and W&M applications, max. 4 load cells	195 x 114 x 59mm	9405 361 30642
PR6130/68	Stainless steel cable junction box	material stainless steel 1.4404, IP 68, for all industrial, applications, max. 8 load cells	200 x 160 x 60mm	9405 361 21682
PR6135	Extension cable	for all applications, grey	D = 9mm	9405 361 35. . 2
PR6135/..A	Extension cable, armoured	for all applications, grey	D = 13mm	9405 361 35. . 9
PR6136	Extension cable	for intrinsically safe applications, blue	D = 11mm	9405 361 36. . 2
PR6136/..A	Extension cable, armoured	for intrinsically safe applications, blue	D = 13mm	9405 361 36. . 9

Type	Description		Dimensions	Order number
PR6007/00N	Mounting kit	material St37, zinc plated, yellow chromated		9405 360 07001
PR6007/00S	Mounting kit	material 1.4301		9405 360 07002

PR6007/00N+S

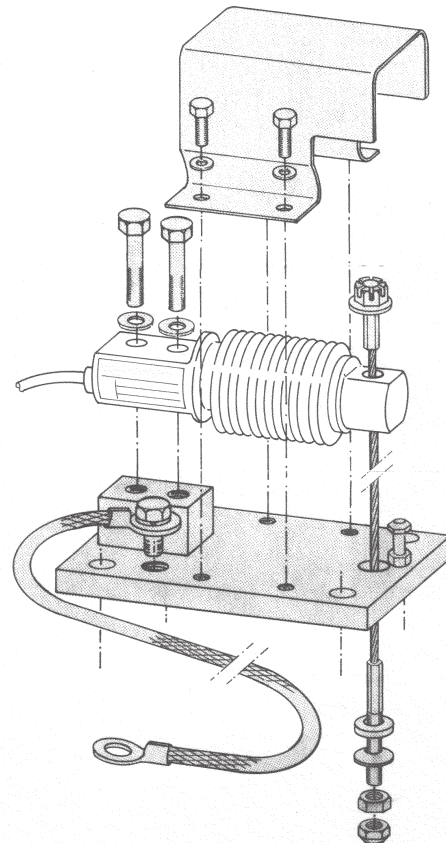
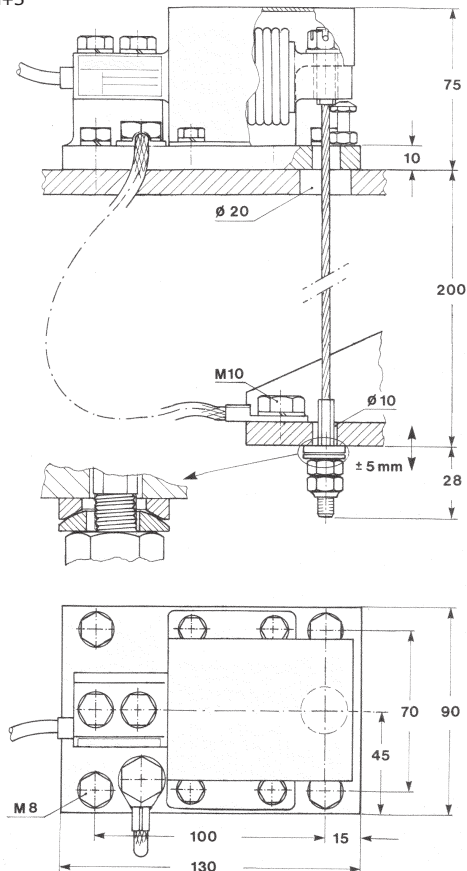

Dimensions in mm

Specifications subject to change
without notice.
Printed in Germany.
n/sart • C
9498 762 07001
Version 09.2005

Sartorius Hamburg GmbH
Meiendorfer Straße 205
22145 Hamburg, Germany
Tel. +49.40.67960.303
Fax +49.40.67960.383
www.sartorius.com